

INTELLIGENT PEACEFUL REVOLUTION



Intention:

There has been a great discovery within the field of conspiracy research. This discovery has generated irrefutable evidence of a shadow government working against the interest of the people.

The intention of this document is to use this undeniable evidence as a catalyst for mobilising the population of Earth into peaceful and intelligent revolution.

The aim of the revolution is to build a system of total and unconditional transparency over all governmental activity.

Total transparency means that the people have full insight into everything that happens in and around government. It will greatly favour those who truly intend to serve and work in the interest of the people while making it impossible for politicians and governmental officials to lie, manipulate, conspire or corrupt.

We rise up peacefully to create the conditions under which conspiracies become impossible.

The first chapter of this document is a presentation of the evidence. To understand it we have to start by getting familiar with the secret society called freemasonry.

The second chapter of this document is a comprehensive explanation of the peaceful revolution for truth. It describes how we organize our way out of the grip of the conspiracy.

The third goes back to the evidence and interprets it from a scientific perspective.

The fourth chapter contains an introduction to hidden knowledge of the mind and works as a basis for understanding the fifth chapter about mind control.

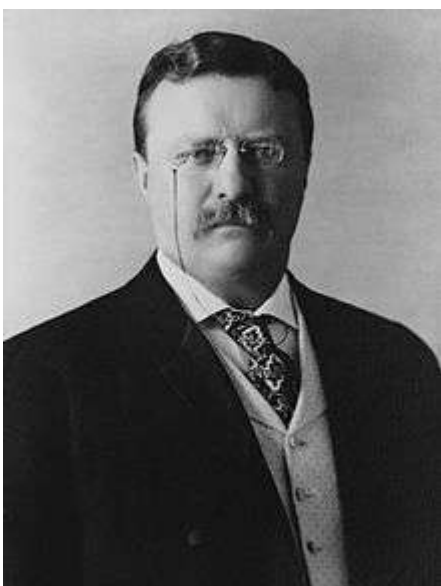
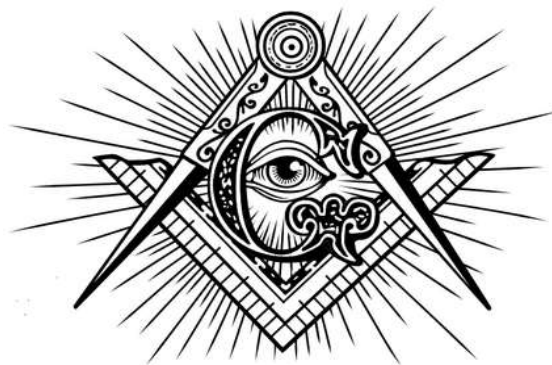

Behind the ostensible government sits enthroned an invisible government owing no allegiance and acknowledging no responsibility to the people.

*- Theodore Roosevelt
26th President of the USA*

What is Freemasonry?



Freemasonry is a secret society.

It means that the members are very discrete about being freemasons and that the secrets of masonry are not revealed to outsiders.

What happens inside the masonic lodges and temples is never spoken about on the outside.



Freemasonry is a secret society with six million official members globally. Masons generally come from the higher class and hold influential positions within society. It's a secret club for politicians, judges, lawyers, business leaders, media owners, investors, bankers and so on.

We don't know what happens inside the masonic lodges but we do know that a large part of those in positions that determine the direction of society are members of, and have sworn allegiance, to the same secret society.



There are six million official masons globally. Official means that they publicly acknowledge membership if asked about it. Many masonic lodges even present registers of their members to those who seek them.

275

Avalon Lodge

N^o. 776 continued

DATE OF INITIATION.	PASSING.	RAISING.	SURNAME.	CHRISTIAN NAME.	AGE.	RESIDENCE.	PROFESSION.	CERTIFICATES.
1905 Sep 10	from	1907	Duder	W. Edwin	40	St Johns	Master Bookbinder	-
" 27	Nov 6	May 1911	Barnes	W. Duncan	42	Pitby's Island	Trader	11.12.06

We don't know if there exist unofficial or secret masons and rites, and how large they might be, but we do know there also exists other less known secret societies.

Freemasonry is a hierarchical organisation consisting of levels, called degrees. As a new initiate you enter at the first degree and get access to the secrets and knowledge of the first degree. You don't get to know all that masonry is, you just get that small piece of the cake that is made for you.

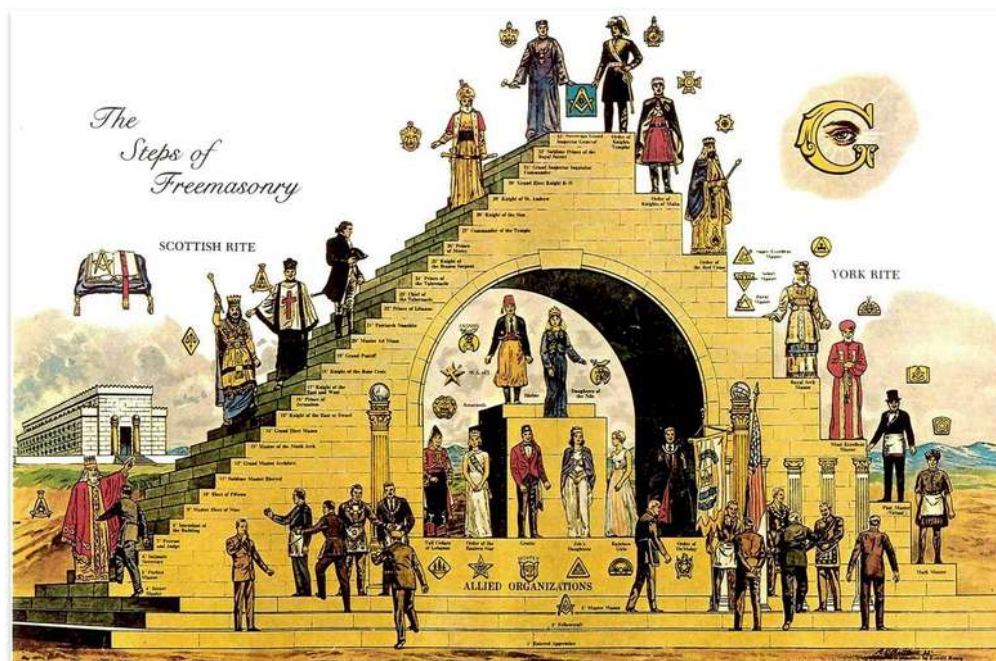

Freemasonry, as an organisation, is divided into rites. Each rite is a structure or system of degrees. The largest rites are the Scottish and the York rite of Freemasonry.

The Scottish rite, depicted as the left side of the stairs, has 33 degrees while the York rite on the right, has 13 degrees.



The new initiate joins a local masonic lodge of a certain rite. He can then climb the degree structure of that rite. Every time that he advances a degree there is a new ritual with new oaths of loyalty followed by access to more knowledge and more secrets as well as a higher position in the hierarchy of that rite.

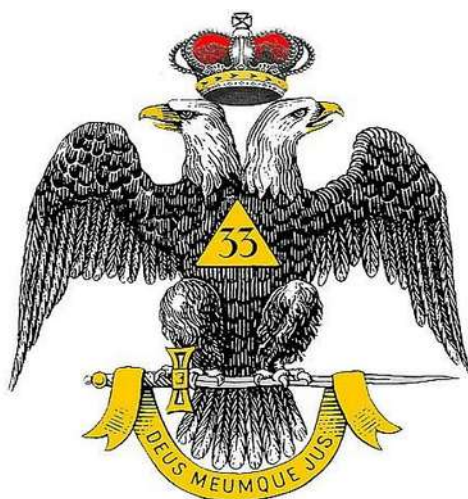

Scottish Rite emblem

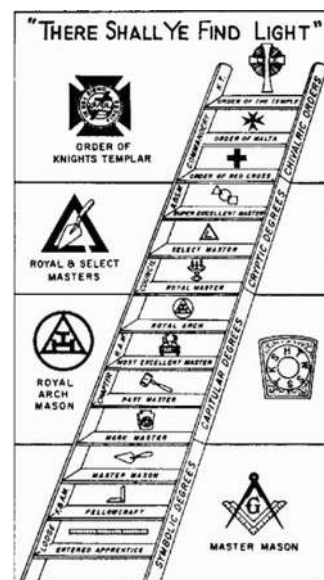

York Rite degree structure

To become a mason you have to believe in a God, a creator or a supreme entity or intelligence of some kind. You cannot be atheist.

Two existing, initiated masons have to recommend you and you will be invited to an interview. If you are approved to become a mason then the initiation ritual awaits you.

Exactly how the ritual is designed and conducted is one of masonry's secrets. There are however some parts of it that have leaked out repeatedly and are believed to constitute the major part of the ritual.

It's said that the initiate is brought in blindfolded, with a rope around his neck and a sword pointed against his heart.

As freemasonry is a secret society the new initiate will not know what masonry is about. He will just have a vague guess depending on what his friends have told him.

It must be a very special sensation to be there dressed in rugs, blind folded with a rope around the neck at the door step to big mysterious secret club for those at the top of society.

There he stand there humbled with his life in the hands of freemasonry. That's the price he has to pay to get it. Unconditional submission – rebirth.

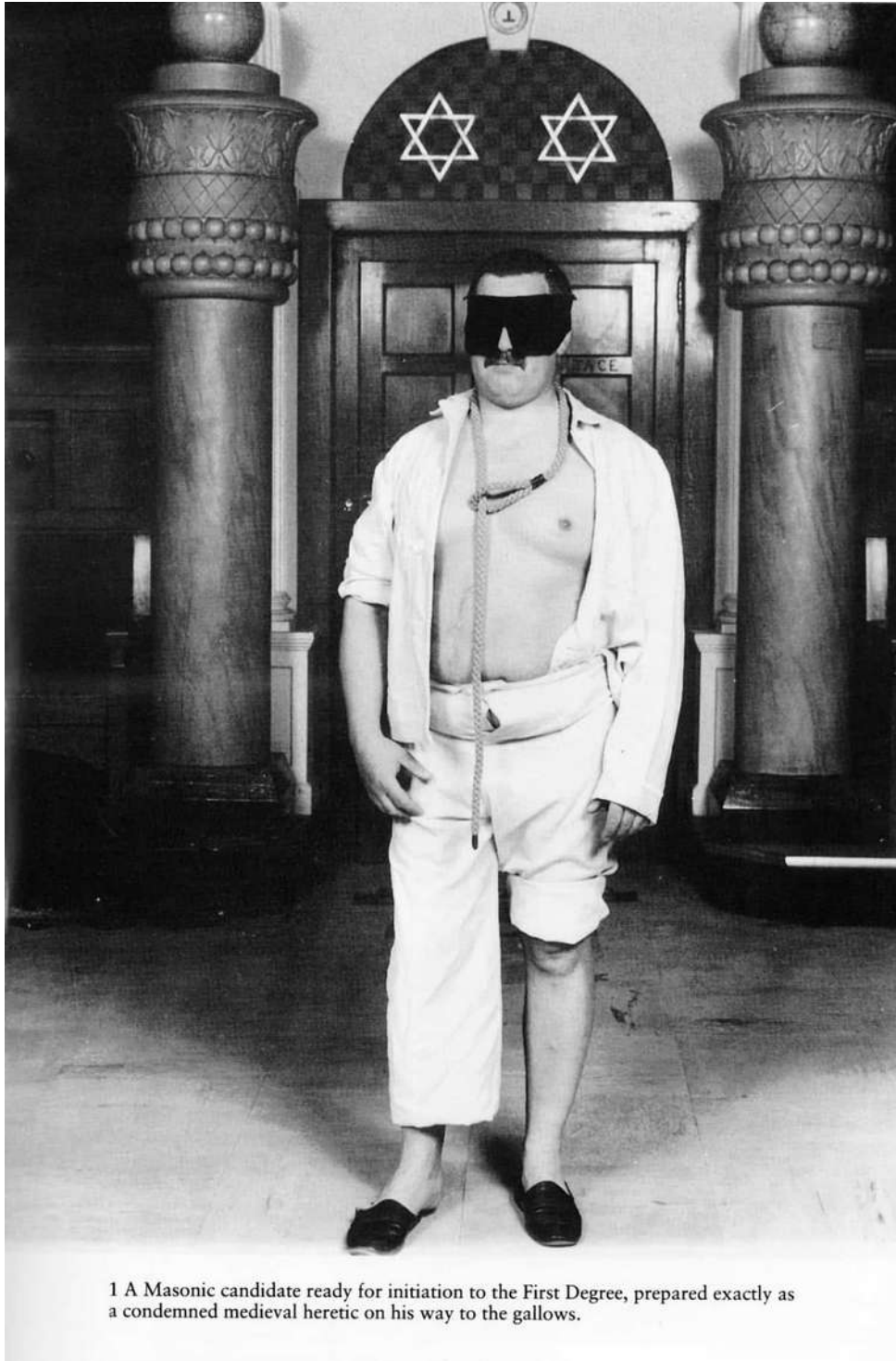

1 A Masonic candidate ready for initiation to the First Degree, prepared exactly as a condemned medieval heretic on his way to the gallows.

He is then brought in to a large hall where he is asked to swear three oaths.

1. Not to reveal any of the secrets, not even in the slightest
2. Give testimony as ordered by masonry, even if it goes against what you believe to be right.
3. Always help your brother masons.

As an initiate into freemasonry you have to swear not to reveal the secrets, lie when given the order to do so and always help other masons.

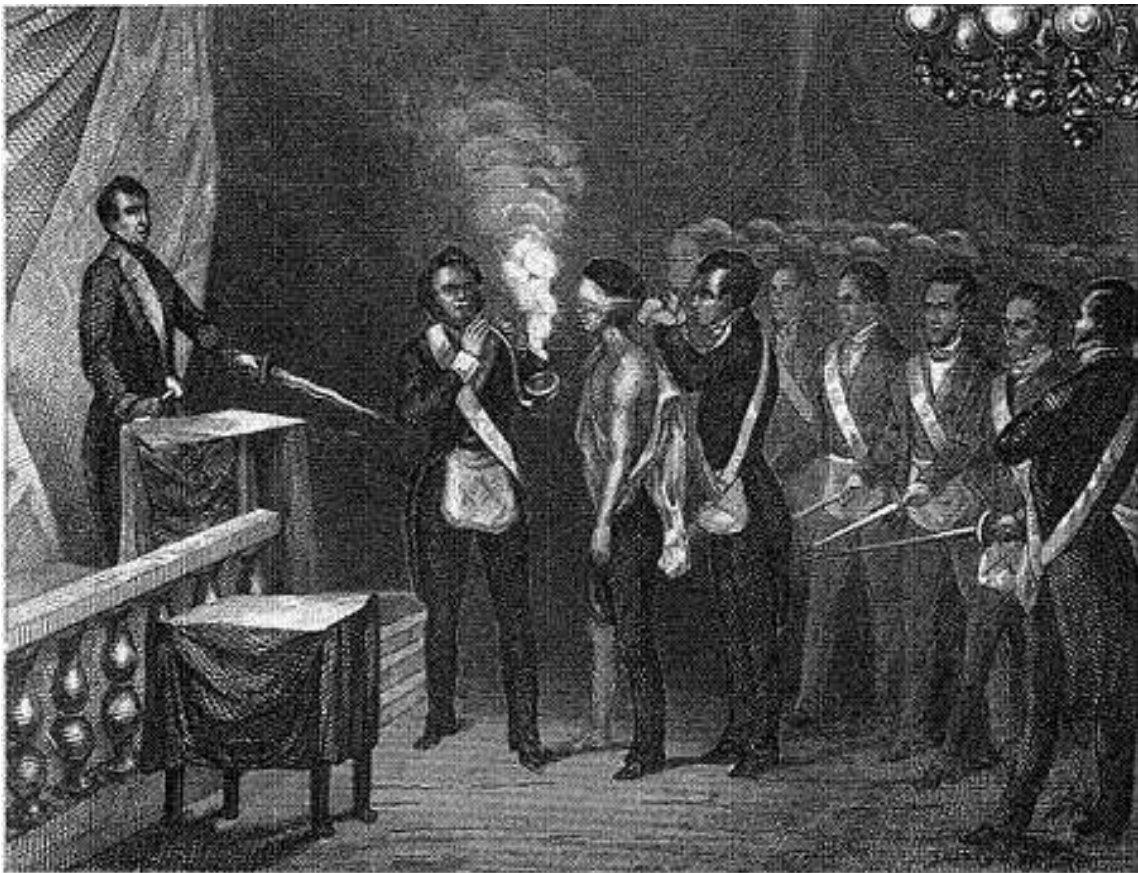

The blindfold is then removed and you see the other members from your lodge standing around you in a circle, holding swords pointed towards your chest. You are told that you will be an enemy of all of masonry would you break your promises even in the slightest. Finally you are welcomed as a fellow brother.

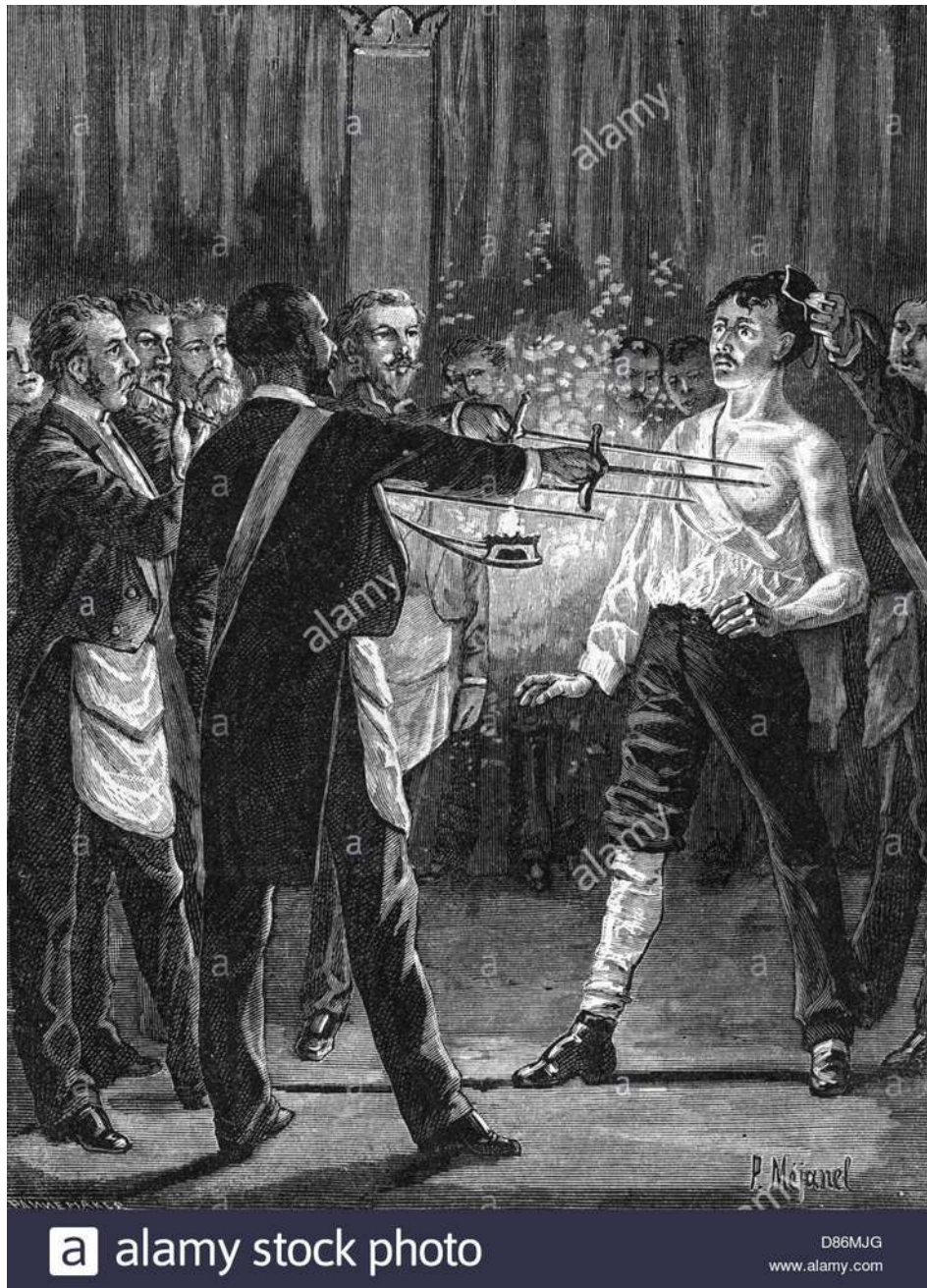

Freemasonry is a huge organisation. It serves many different purposes for many different practitioners. Different lodges and different rites focus on different aspects of masonry. What they all have in common, and what masonry basically is about, is described by the masonic logo for those who know how to read it.



The logo of Freemasonry consists of three different objects. There is a compass, a G and a square.

One interpretation of the logo is to see it as representing body, mind and soul.

The compass is then the mind and thoughts.

The G is the soul or emotions.

The square is the body or action and speech in the physical world.



The compass and the square are tools. This interpretation gives us mind and body depicted as tools for studying and working on the soul; or on the subconscious mind.

We can see masonry as the art and the knowledge of how to use mind and body to work on the soul or how to use thought and action to work on emotions and the subconscious mind.

Occult knowledge

The word occult means hidden or covered. Occult knowledge is knowledge that is hidden or covered.

The secret society “Freemasonry” is a school of occult knowledge.

The most interesting knowledge to hide or occult is the knowledge about consciousness and how the mind works.

If you know how a human functions, but they don't, then you can use that knowledge to manipulate their behaviour.

The more of a knowledge advantage you have, the more can you control the behaviour of others without them knowing.

Freemasonry as a secret society is a school of occult knowledge. To get access to the knowledge you have to submit to the conditions set by freemasonry. You have to swear secrecy and loyalty.

One characteristic of occult knowledge is the use of symbols as part of the language.

There are concepts and aspect of the mind that are easier to understand through pictures and visuals rather than through words.

The use of symbols to represent concepts also helps to occult the knowledge. Words can be understood by everyone but symbols are only understood by those who are initiated into the knowledge and the concepts that they represent.

One example of how symbols are used in masonry is the tracing boards. This picture is the first degree tracing board in masonry.

It is a study aid used for the teachings of the first degree. Every little detail is there as a reminder of a concept or aspect of knowledge.



The occult knowledge - the knowledge of the mind - can be used to do good or to do bad.

Benjamin Franklin



Masonic labor is purely a labor of love. He who seeks to draw Masonic wages in gold and silver will be disappointed. The wages of a Mason are in the dealings with one another; sympathy begets sympathy, kindness begets kindness, helpfulness begets helpfulness, and these are the wages of a Mason.

AZ QUOTES

The official purpose of freemasonry is the improvement of man towards becoming better persons. This self-improvement is a large part of what masonry is but it's not the only part. Masonry is many different things for many different practitioners. One of those things is a shadow government that controls the official governments and the large hierarchies of this world.

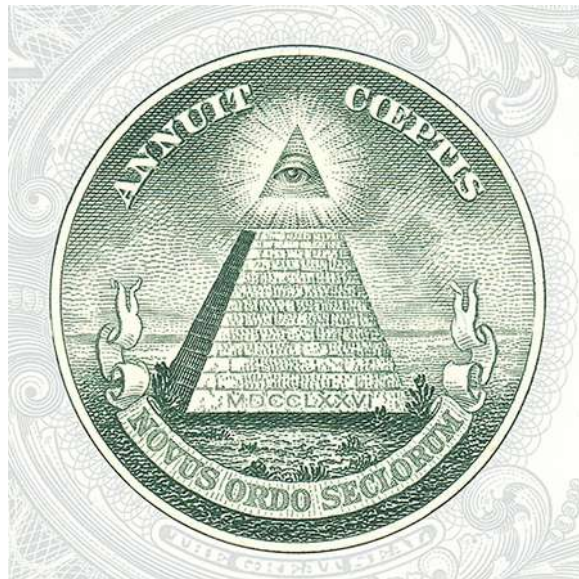

The evidence

Freemasonry is a secret society. They are very discrete about their membership, which means that they never openly ask others if they are masons. Instead they have symbols, numbers, handshakes, gestures and special wordings that they use to discretely communicate their membership in ways that only other masons will recognize.

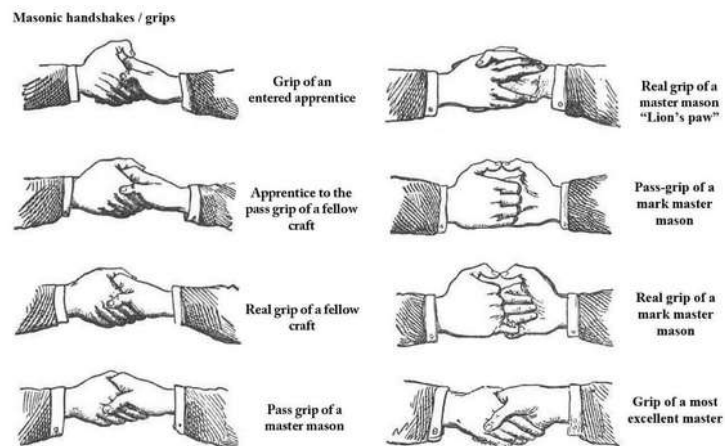

What I have showed you so far is not part of the evidence; it's merely examples of masonic symbolism. It's a known fact that Walt Disney was a 33rd degree mason. It's no secret and he did not deny it, but it does not prove that there is a sinister conspiracy.

What I have showed you so far is the context of the evidence and that context is masonic symbolism and numerology.

The great discovery that has been made is that the numerological part of the secret language of masonry has been found and decoded.

The numerological stamp that masonry put on everything that belongs to them is now found, cracked and about to be exposed.

We have the key to their numerological pattern.

You will soon understand the magnitude of this discovery.

The numerological pattern:

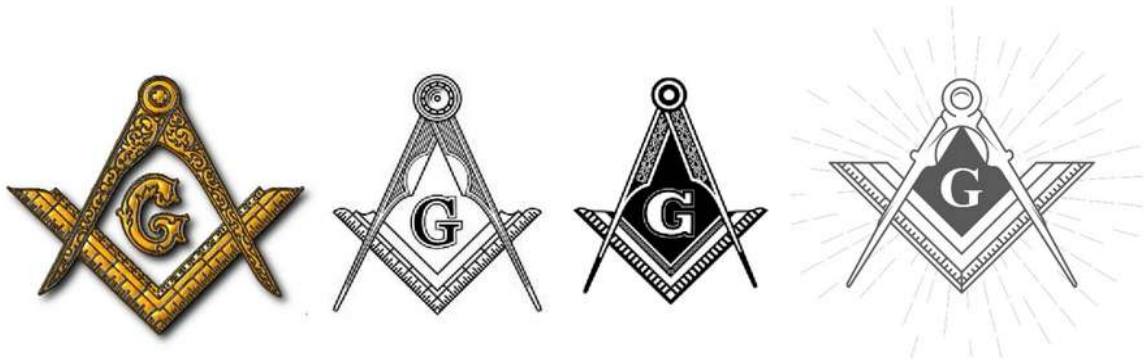

The masonic logo comes in many different depictions.

It always contains the compass, the square and the G but they have different designs in different depictions of the logo.

One of these depictions is what I would like to call a numerological masterpiece. It is also the key to deciphering the code used to secretly communicate masonry.



In this numerological masterpiece the compass holds 47 degrees. If you measure the angle from the eye of the compass and to the point of the legs you get 47 degrees.

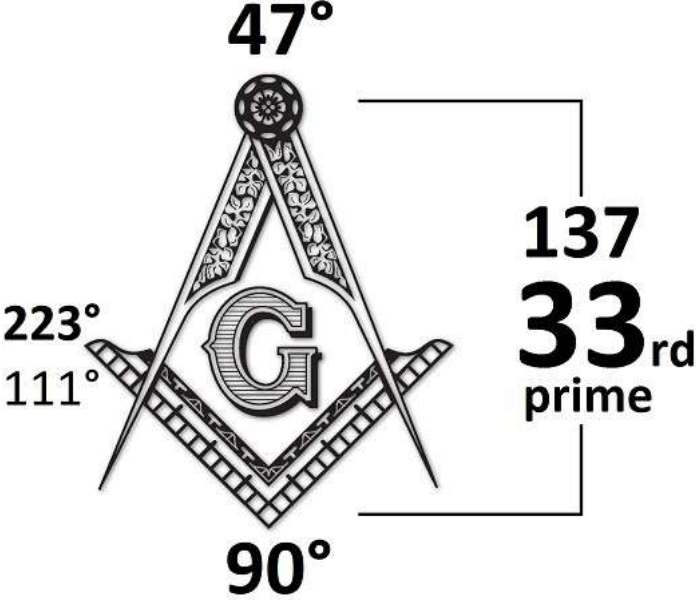

The square is a right angle and it's always 90 degrees in all the depictions.

As a figure with four corners will have 360 degrees in total it means that G holds 223 degrees or 111,5 on each side. $(360 - 90 - 47 = 223)$

If we add up the 47 of the compass with the 90 of the square we get 137. The number 137 is the 33rd prime number: the highest known degree in masonry.

This version of the masonic logo is the key to the secret code or numerological pattern used by the masons.

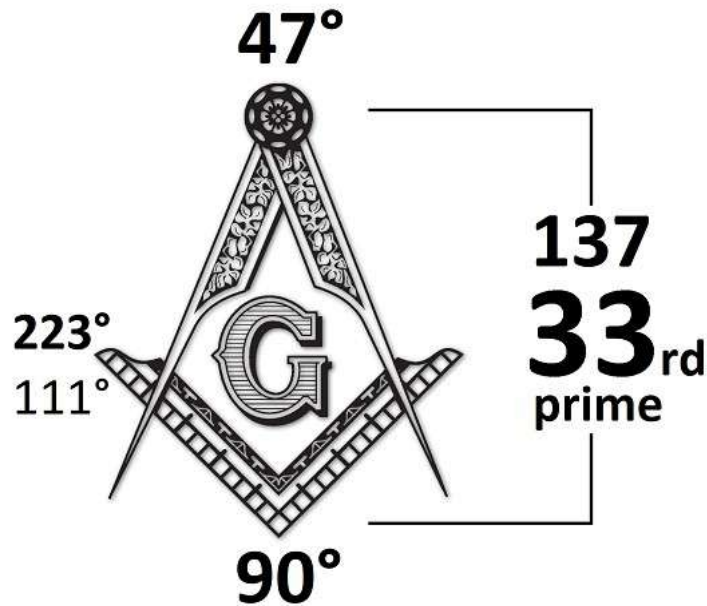

There are three main parts to the numerological pattern built around the Masonic logo.

1.) We have combinations of the 47 of the compass and the 90 of the square in different creative ways. Sometimes the 7 of the G is added.

2.) We have all the different G's in a continuous alphabet: 7, 33, 59, 85, 111, 137, 163, 189, 215, 241, 267, 293, 319....

3.) And we have the degree structure of the Scottish and York rites of freemasonry: 33 & 4x13

The pattern is described in appendix 1.

The following examples of this numerological pattern are not the evidence. These examples might at first seem a bit weak and far-reaching but please have patience, the evidence itself is on another level.

The purpose of these coming examples is to connect the numerological pattern with events and organisations that we do know there is masonic involvement in.



The first example of the numerological code comes from the creation of the United States of America and the adaptation of the “Great Seal” as the principal national symbol of the United States.

The Great Seal can nowadays also be found on the backside of the dollar bill.



The United States of America was created through the signing of the Declaration of Independence.



This document was signed by a total of 56 persons.

8 of them are confirmed freemasons.

16 of them are suspected to have been freemasons.

The total amount of freemasons and members of other secret societies was probably higher but we know for sure that at least eight of them were masons.

We can safely assume that they knew the masonic meaning of the number 47 as they decided for Independence Day to be 4/7.

$(56 \text{ signers} = 47 + 9+0)$

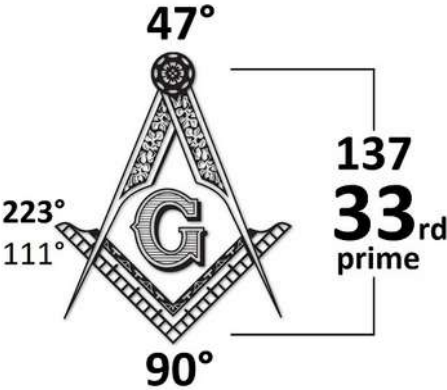

One of the signers of the Declaration of Independence was George Washington. He also became the first president of the United States of America (USA).

George Washington was a freemason and when he was sworn in as president he used a bible from his masonic lodge.

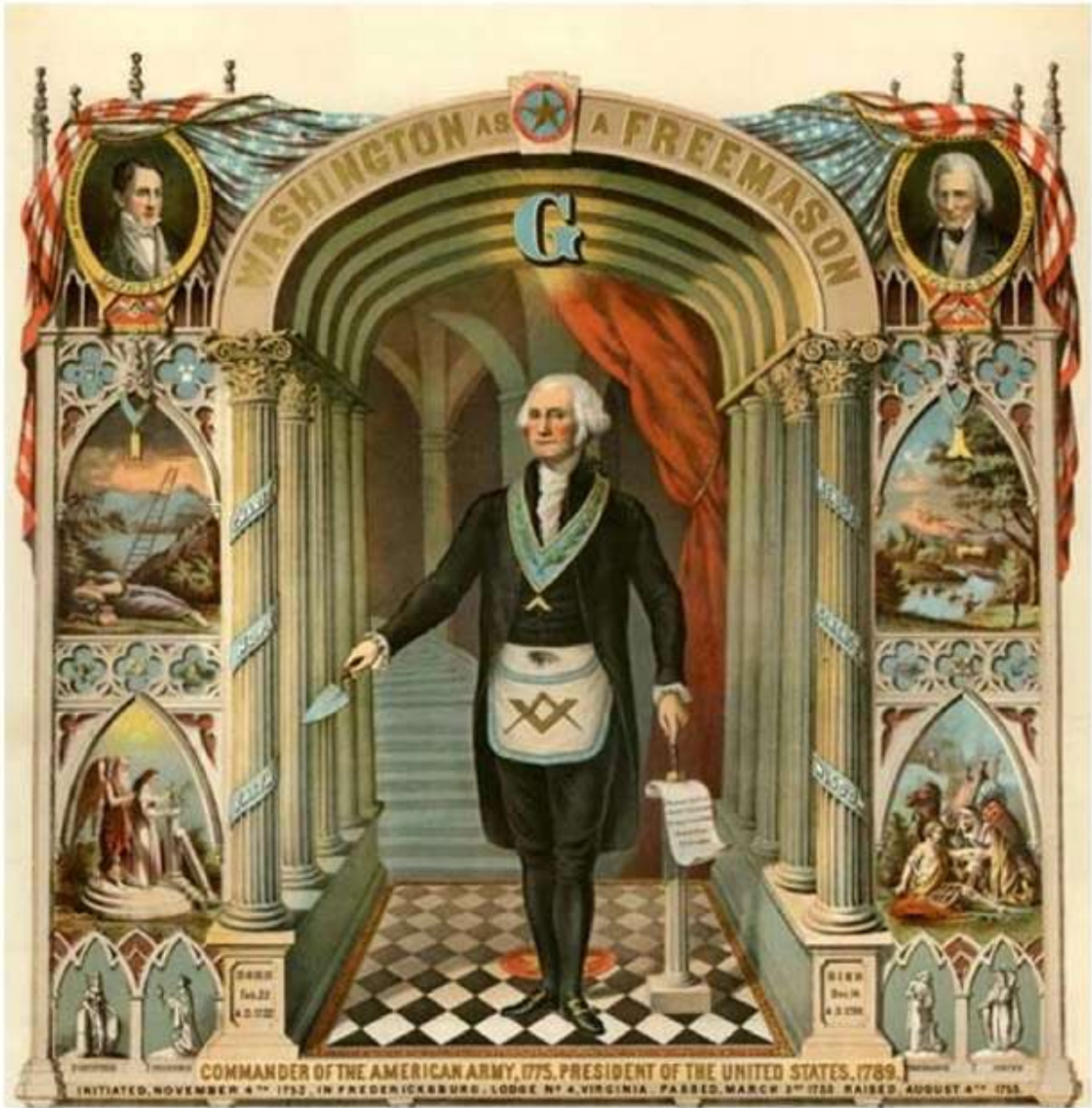



The Great Seal of the United States comes in two parts. The first part is the eye of providence and the second part is the Bald Eagle. This is a masonic masterpiece.

The first part, the eye of providence, is the pyramid with the all-seeing eye on the left side. To see how elegantly it communicates masonry we need to visit the Temple of Solomon.

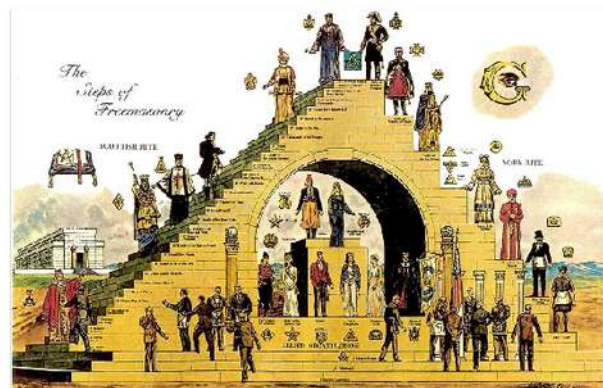

Do you remember these “Steps of Masonry”, showing the degree structures of the York and the Scottish rite of freemasonry? To the left of the stairs there is a temple called the temple of Solomon.

Solomon is a legend within freemasonry and some will even claim him to be the first freemason. What ever the case, Solomon and his temple are central to freemasonry.

The seal of Solomon is two overlapping triangles within a circle. One triangle represents the feminine aspect of consciousness and the other the masculine; just like Yin and Yang. That they overlap shows that the mind is balanced and harmonized. More about this in the fourth chapter.

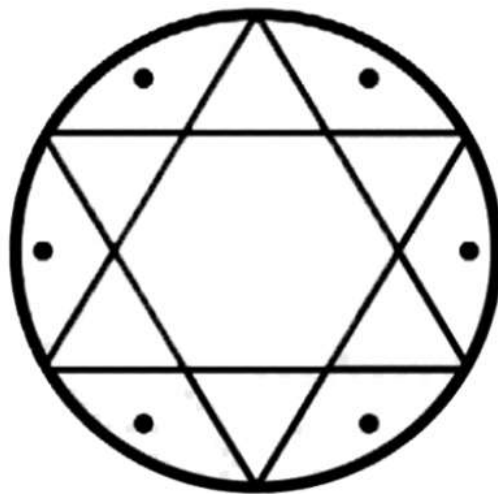

That is the seal of Solomon. Now let's get back to the back of the dollar bill and the great seal of the United States.

Under the pyramid with the all-seeing eye there is written “THE GREAT SEAL”.

If you are a mason then the great seal is the seal of Solomon.



Let's use the pyramid as one of the triangles in Solomons seal and then add the other triangle.

The result is a six pointed star showing us the letters in M-A-S-O-N and the all-seeing eye.

Not bad, hu?

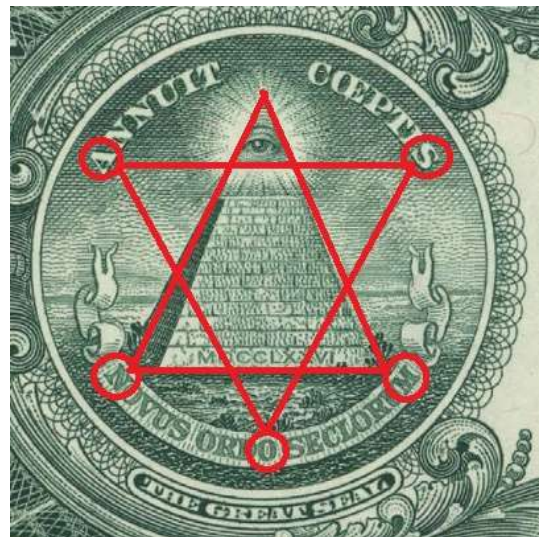

The symbol of the Unites States is a pyramid with an all-seeing eye an and elegantly hidden anagram for MASON.

The text around the pyramid on the back of the dollar bill says: “ANNUIT COEPTIS – NOVUS ORDO SECLORUM”.

It translates into: “It favours our project – a new world order”.



This building is called the House of Temple. It is where the 33rd degree masons meet.

It's built with 33 pillars, each pillar 33 feet high to honour the 33rd degree of the Scottish Rite. On the roof of the House of Temple is an unfinished pyramid in 13 levels of bricks.

The unfinished pyramid in the seal of the United States is also made up of 13 levels of bricks.

Can it be for the 13 degrees in the York Rite of freemasonry?



That's the pyramid, now to the Bald Eagle.

Do you remember the degree structure of the Scottish and the York rites of Freemasonry?

The Scottish rite has a total of 33 degrees. There are 32 regular degrees that can be reached by effort, commitment and money, and then there is a 33rd honorary degree that you can only reach by invitation.

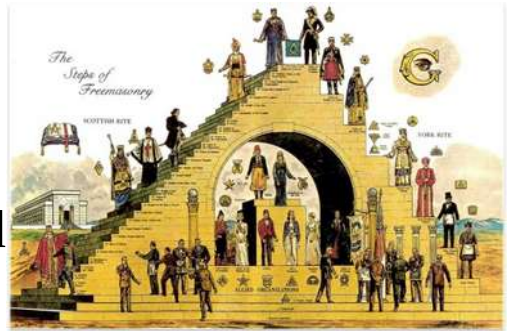

The Bald Eagle has got 33 feathers on one wing and 32 on the other. This is for the 32 regular degrees and the 33rd honorary in the Scottish Rite.

There are also 9 tail feathers making it a total of 74 or 47 mirrored.

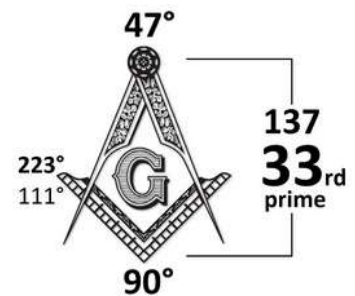

The York Rite has 13 degrees in four sections.

The Bald Eagle holds 13 arrows and 13 leaves.
There are 13 stripes on its chest and 13 stars
above its head in the shape of Seal of Solomon.

13x4 for the 13 degrees in four sections of the York rite.

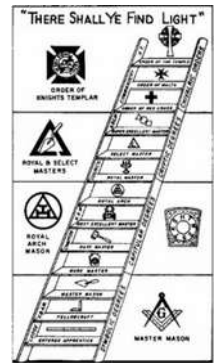

Around the 13 stars is a circle of 28 small lines or rays.

If we see this circle as the eye of the compass in the masonic logo and those 28 short lines as degrees then we have a circle with 4×7 degrees at the top of the top of the figure.

At the bottom we have 9+0 feathers in the shape of a V.

Is it a very clever way to hide a reference to the logo?
After all, it's part of the same seal as the pyramid pointing out MASON.



At the very top
 $4 \times 7 = 28$ rays

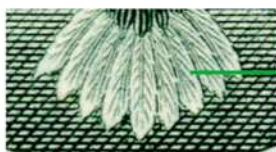

At the very down
9 feathers

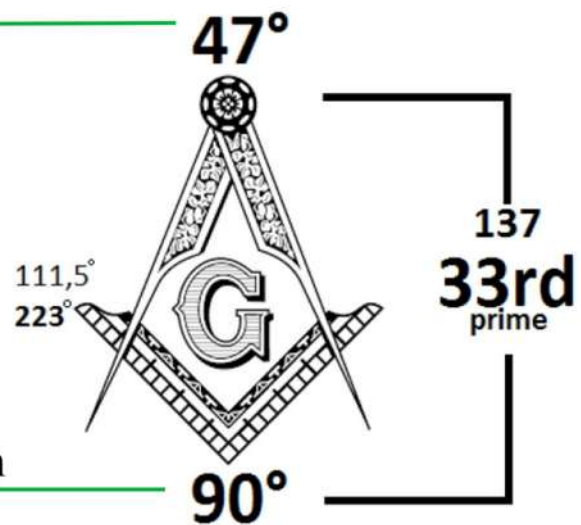

We know there exists a secret society called Freemasonry.

We know it has six million official members globally from high positions within society.

We strongly believe these members are very discrete about their membership and that they have sworn an oath not to reveal the secrets of masonry, to give testimony as ordered by masonry and to always help their fellow masons.

We know what the logo of masonry looks like and we know there is one version of the logo that gives us the following constellation of numbers:

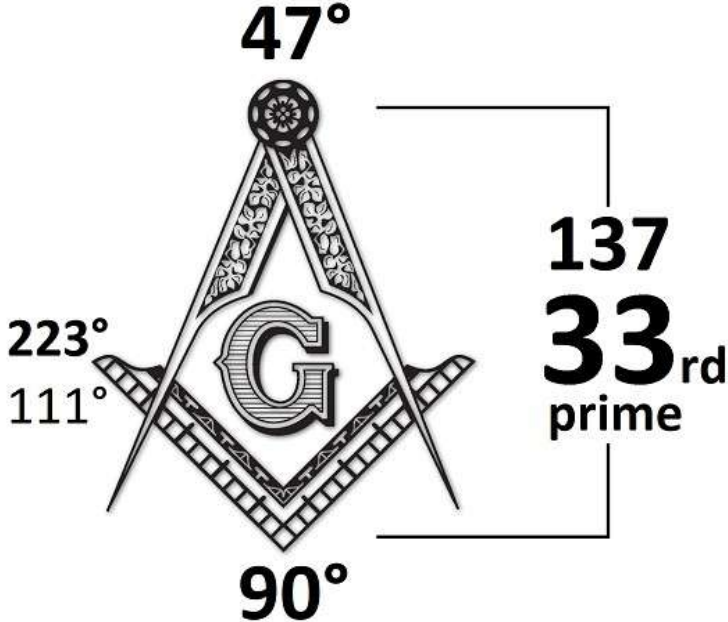

The United States of America were created on the 4/7 by 47+9 signatures.



The first president was a mason who used a masonic bible in the inauguration.



The symbol of the USA is a pyramid with an all-seeing eye and an anagram for M-A-S-O-N as well as an eagle hiding the degree structure of the Scottish and York rites of freemasonry as well as a reference to the logo.



This symbol is also found on the backside of the one dollar bill: the most used currency in the world



This is what we know, but this is not the evidence. These are just examples that will help you understand the evidence once it is present to you.

The next example of masonic symbolism and numerology is also from the USA. It's the National Aeronautics and Space Administration known as NASA.

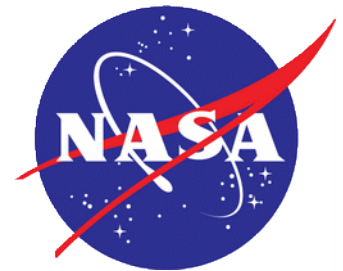

NASA is an institution with a documented history of many known masons.

One of the most prominent of them is probably Fred Kleinknecht. He was the head of the Apollo missions as well as a 33rd degree mason.

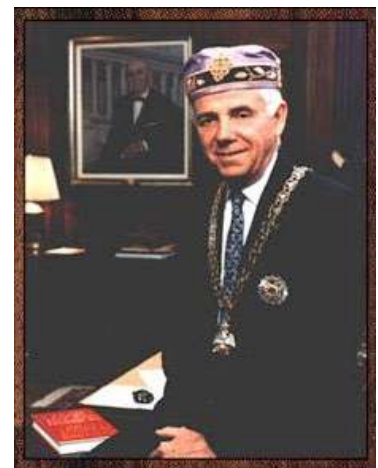

C. Fred Kleinknecht
Sovereign Grand Commander

Edwin Webb was the 1st administrator of NASA from 1961 to 1968.

1st administrator is the highest position within NASA.

He was also a 33rd degree mason.

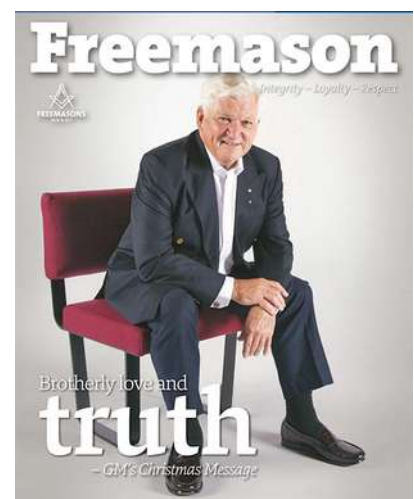



Many of the most famous astronauts have also been official masons. Both Wally Schirra and “Buzz” Aldrin were 33rd degree masons of the Scottish Rite.

“Buzz” Aldrin was together with Neil Armstrong the first human to walk on the moon.



In a letter written by Buzz Aldrin to a fellow 33rd degree masons he describes that he carried with him a masonic flag on the Apollo 11 flight to the moon.

staffs. My greatest pleasure, however, was to be able to present to you on this occasion the Scottish Rite Flag which I carried on the Apollo 11 Flight to the Moon--emblazoned in color with the Scottish Rite Double-headed Eagle, the Blue Lodge Emblem and the Sovereign Grand Commander's Insignia.

Illustrious Luther A. Smith, 33^o
Sovereign Grand Commander
Supreme Council, 33^o
Southern Jurisdiction, U.S.A.
1733 16th Street, N.W.
Washington, D.C. 20009

Dear Grand Commander:

It was a great moment in my life to be so cordially welcomed to the House of the Temple on September 16, 1969, by you and Grand Secretary General Kleinknecht, 33^o, and also the members of your staffs. My greatest pleasure, however, was to be able to present to you on this occasion the Scottish Rite Flag which I carried on the Apollo 11 Flight to the Moon--emblazoned in color with the Scottish Rite Double-headed Eagle, the Blue Lodge Emblem and the Sovereign Grand Commander's Insignia.

I take this opportunity to again thank you for the autographed copy of your recent book, entitled "Action by the Scottish Rite, Southern Jurisdiction, U.S.A.," which is filled with a wealth of information about your Americanism Program sponsored by the Supreme Council, participating activities and related activities of the Rite.

Cordially and fraternally,

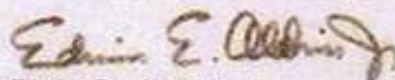

Edwin E. Aldrin, Jr.
NASA Astronaut

These are just a few examples of masons in NASA. It's easy to find more through a simple search. Now to the masonic symbols and numbers of the logo of NASA



We can start by counting all the objects in the logo. There are four letters (NASA), a red vector, a comet, 40 stars and a blue background.

It consists of totally 47 objects. This is one hint that the organisation might be masonic as 47 is one of the primary numbers in the Masonic pattern.

- ★ 40
- NASA 4
- ↗ 1
- ☉ 1
- $\frac{1}{47}$

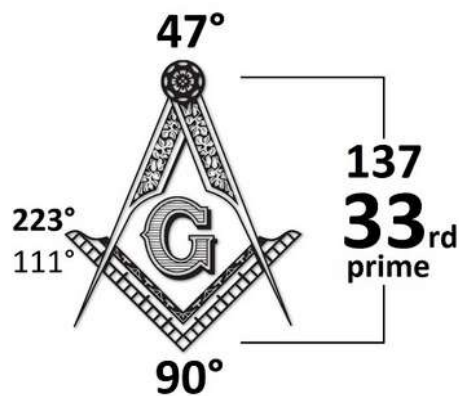

Now remember that $47+90$ is 137, the 33rd prime and that G is the seventh letter of the alphabet. This means that if we play around with the numbers in the masonic logo we can get 7 and 33 quite easily.

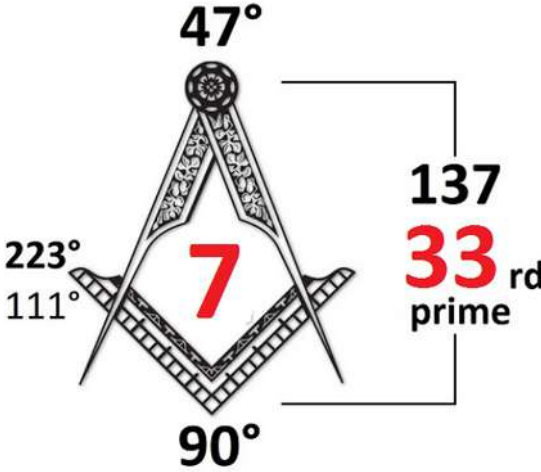

The logo of NASA contains a red vector which could be seen as a reference to the compass. Inside the red vector are 7 stars and outside it 33. We have the same 7-33 compass constellation both in the masonic as well as in NASA's logo.

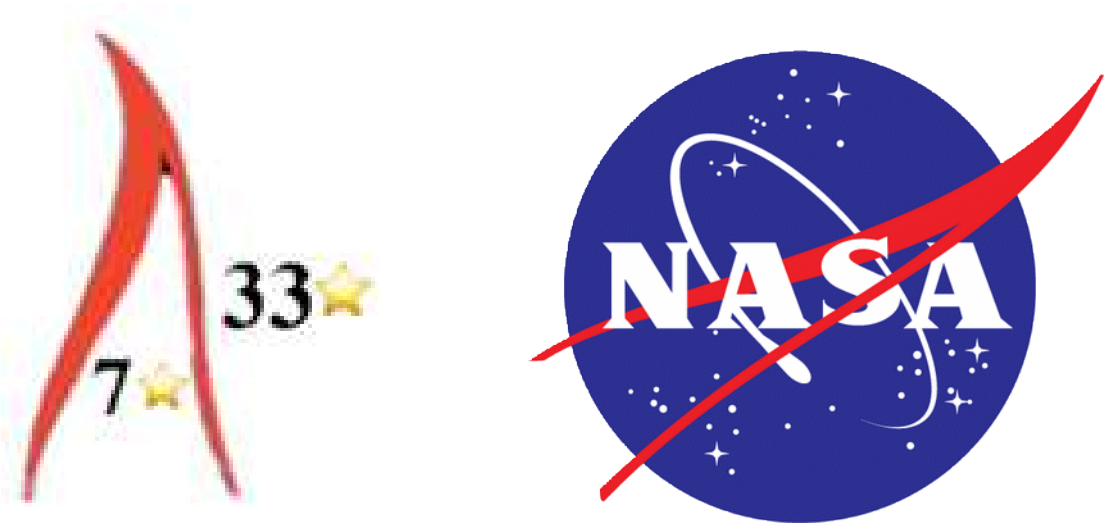

NASA is an institution full of known masons, both as astronauts as well as in the administration.

The logo of NASA consists of 47 objects, one of them a red vector with a 7-33 stars constellation.

The next example of masonic symbolism and numerology comes from the largest political organization in the world: the United Nations.



Here we have the map of the world on a pattern of 33 sections. There are 4 rings with 8 part in each and one central circle.

$$4 \times 8 + 1 = 33$$

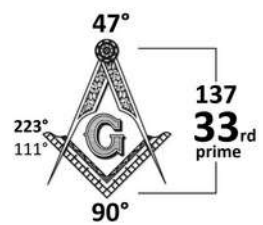

Around the map of the world are a total of 28 leaves.

So we have the world on 33 surrounded by 4x7 leaves.

If you make the logo for an institution like the United Nations in a world of six million masons, and you don't want to symbolise masonry, then you make sure these numbers do not occur. Especially not number 33.

If these numbers found in the UN logo were not an intentional reference to masonry then someone would have stopped the logo before it was approved and used.

This cannot happen by accident. Especially not since the United Nations were created during the presidency of Franklin D. Roosevelt who also was a mason.



The examples that I have shown you so far are innocent. They give a hint that there is a conspiracy but they do not reveal the sinister methods of the conspiracy.

The main evidence is an exposition of nine eleven as a freemasonic ritual. I will show you that the numerological pattern occurs in nine eleven with such incredible frequency that it cannot be the result of coincidence.

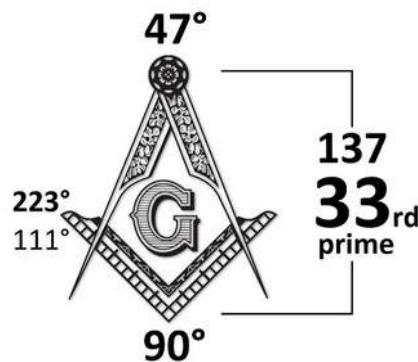

The numbers of nine eleven; the date, the point of time for the attack and the amount of passengers and casualties are all handpicked to maximize the references to this one version of the masonic logo. It is obvious and overwhelming for those who know the code while at the same time totally impossible to find for those who have no clue.

Let's get to it.

Nine eleven as a masonic ritual:

The main theme of the numerological pattern is to combine the 47 of the compass with the 90 of the square in different creative ways.

So, let's say that we want to combine the 47 and 90 to get a date. One easy way of doing this is to take 47 and make it $4+7$ and then do the same with 90 to get $9+0$.

$4+7$ is of course 11 and $9+0$ is 9. The result is 9/11.

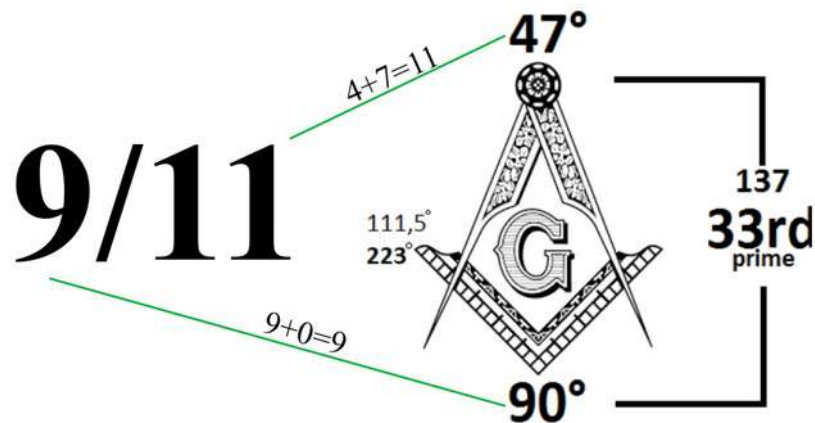

Nine eleven is also the 254th day of the year. This means that there are 111 days remaining to the end of the year.

Can nine eleven be the one day of the year with the strongest references to the numerological pattern?

The attacks of that day started at 8:46:30 when flight 11 crashed into the north tower of the world trade centre.

8:46:30 is the 47th minute of the 9th hour.

47th minute for the compass
 9th hour for the square



Flight 175 then crashed into the south tower at 09:03, or at 09:02:59 to be exact.



If we use subtraction instead of addition then the 47 of the compass becomes $4-7=3$ and the 90 of the square become $9-0=9$.

09:03 was also chosen as a reference to the compass and the square.

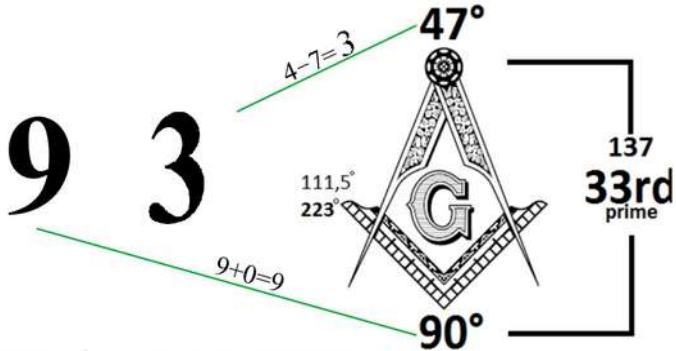

Passengers and casualties:



Flight 11

Flight 11 carried a total of 92 persons consisting of 81 passengers and 11 flight crew.

Flight 175 carried a total of 65 persons consisting of 56 passengers and 9 flight crew.



Flight 175

There is nothing special about 92 and 65 but if we see this as one attack instead of two then the picture changes.

The two flights that hit the twin-towers carried a total of 137 passengers and 9-11 crew.

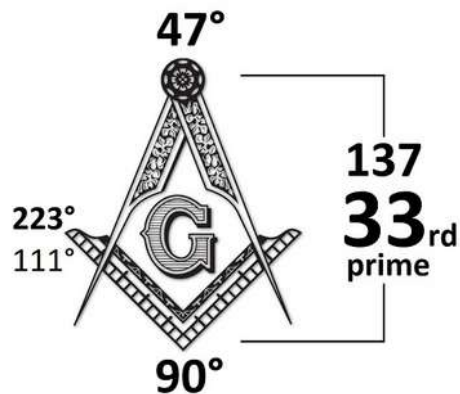
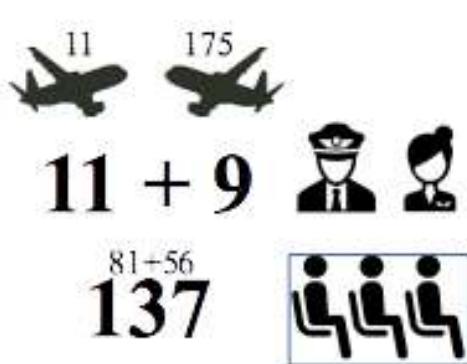

Both planes also carried a 9-11 individually if we separate crew from passengers and then apply the same logic as when connecting 9/11 to 90 and 47.

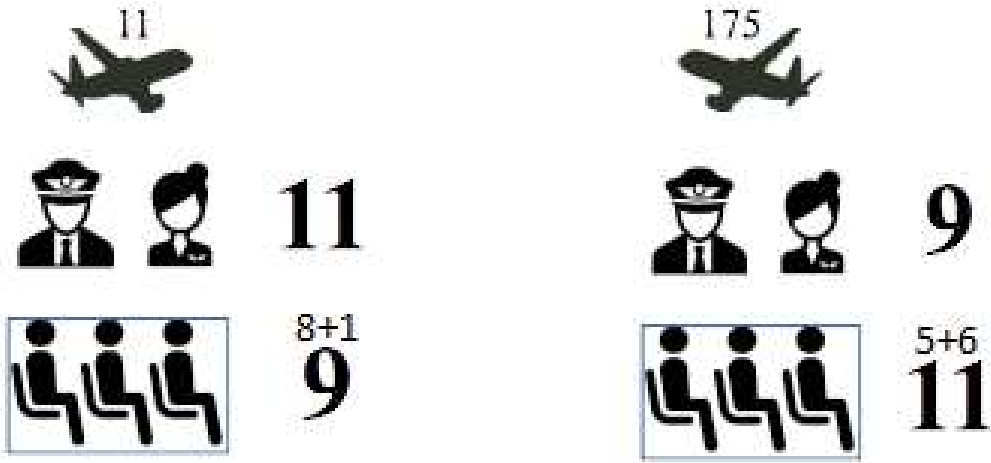

The date, the time of the attack and the constellation of passengers and crew on the two planes that hit the twin towers are chosen to discretely maximize the amount of references to the Masonic logo used for the secret code.

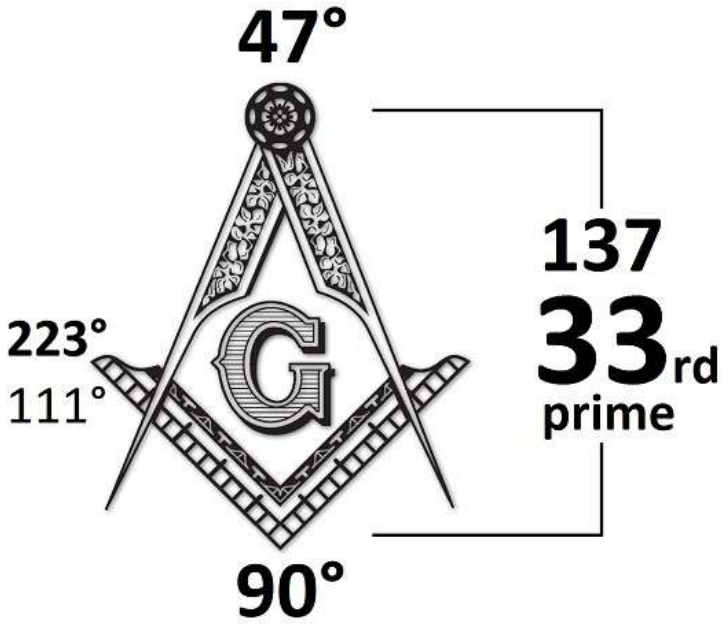

There are several theories of what actually happened on nine eleven. One of these theories is the no-planes theory claiming that no planes hit the twin towers*.

It says that the twin towers were rigged with explosives and that the videos of the planes hitting the towers were just computer generated animations.

If this is true then those explosives can be detonated at any chosen point of time, for example at 8:46:30. The number of passengers and crew can also be invented.



<= To early
detonation?

**The documentaries that present the no-planes theory generally use false and easily debunkable evidence. This should not be understood to mean that the theory is false as it can be an elaborate way of hiding an actual truth. If the evidence for a claim is false then it's all too easy to mistakenly assume the claim also to be false.*

If there were no planes and the towers were in fact rigged with explosives then they can also choose what floors to rig those explosives on.

It's said that flight 11 hit the north tower between floors 93 and 99.

(Some sources say 92 but most agree on 93)

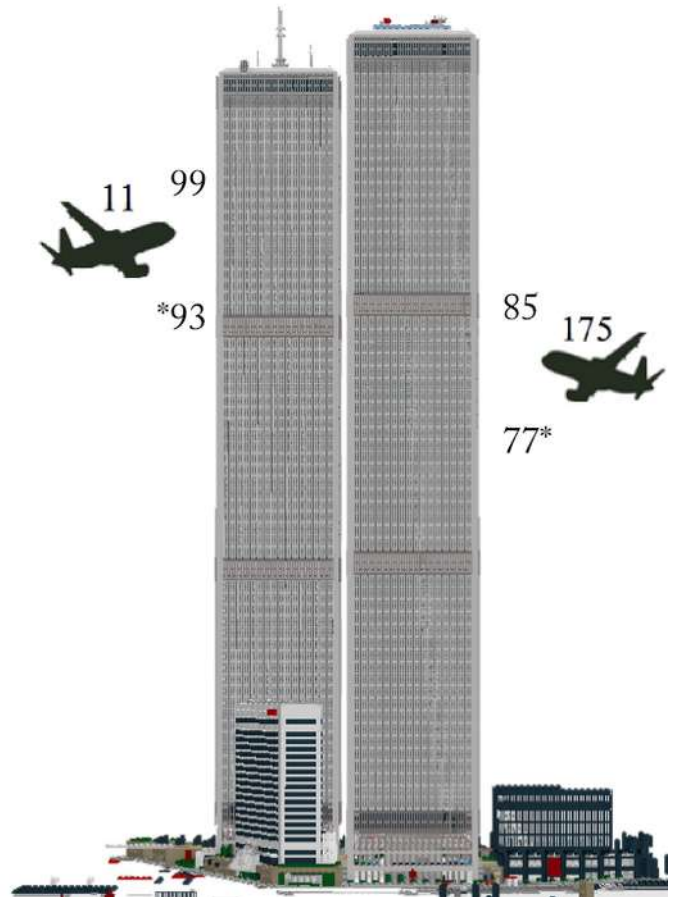

We already saw the number 93 and how 9 is for 9-0 of the square and 3 is for 4-7 of the compass.

99 was probably chosen because it is 9×11 and the best alternative within a reasonable distance from 93.

77 is a number that we will see a lot of. It is one of the most used numbers and it will be explained later. For now we will take it as a visual reference to the square and the compass.

85 is the 4th G or the 4th $7 = 47$. (Please see the appendix.)

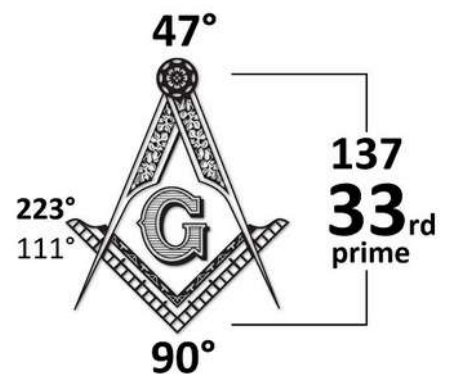

This secret communication of the freemasons; this numerological stamp that they put on that which belongs to them, is designed so that it is extremely obvious for those who are aware of the conspiracy and the code while at the same time being impossible to find for those who do not even know there is a conspiracy and a code to look for.

It's designed to be obvious and bold while at the same time being too elusive to be used as evidence.

We live in a world of six million official masons. They have all sworn an oath to protect the secrets of masonry. An overwhelming majority of these six million masons were not involved in orchestrating nine eleven. Most are probably even against it but since it carries the stamp of masonry they are forced to help protect the secret.

As nine eleven carries the stamp of masonry all masons have to help protect the secret, even those who are against it.

The Pentagon:

The Pentagon was allegedly hit by flight 77 at 09:37. Flight 77 carried a total of 64 persons consisting of 58 passengers and 6 crew. 125 employees of the Pentagon died as a consequence of the impact.

The official story tells us that the plane hit the Pentagon where it says “Entry” and travelled through three layers of buildings made of reinforced concrete before leaving “Exit Hole”.

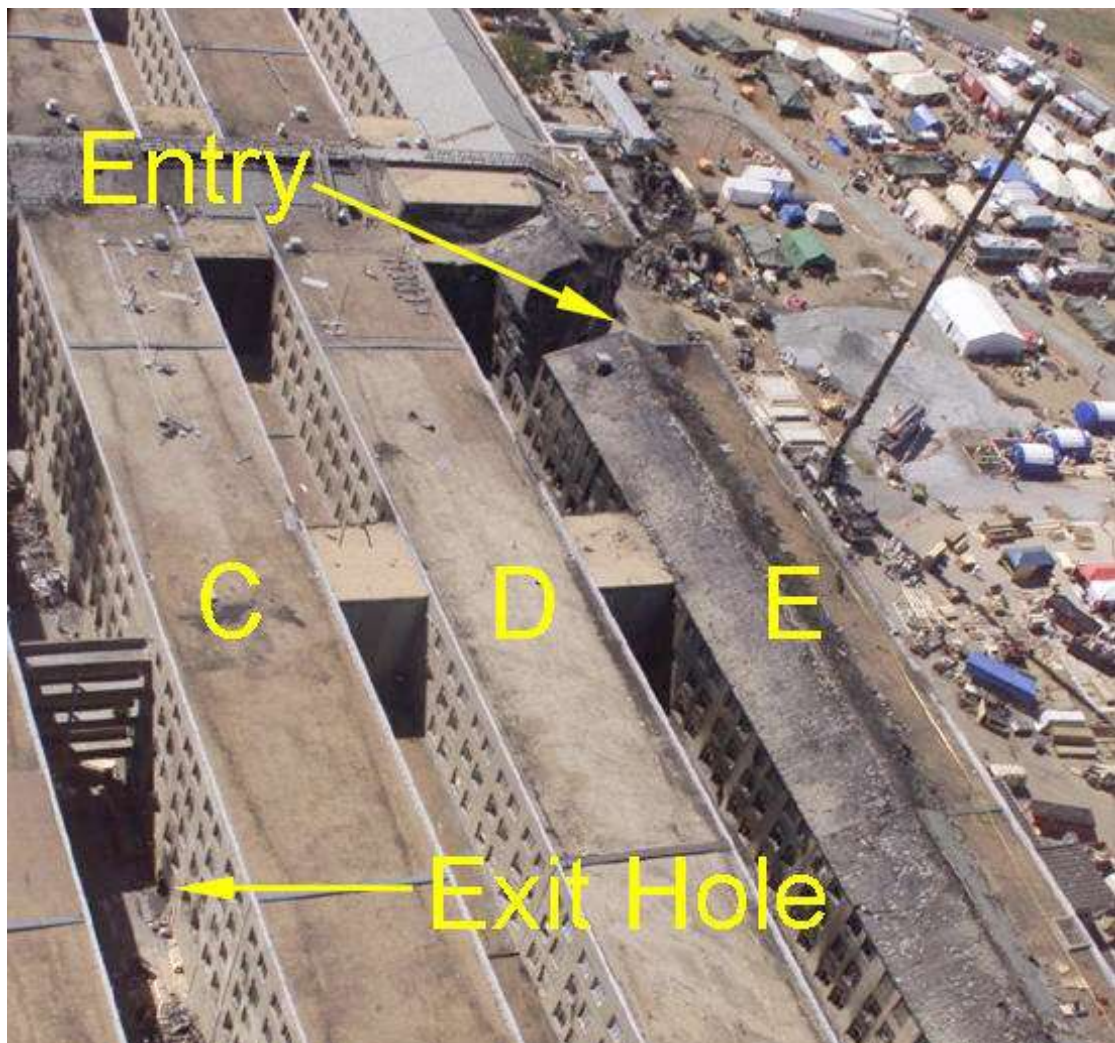

This is the exit hole made by flight 77



The wall where the plane entered the Pentagon remained standing for a while before collapsing. This is what it looked like while still standing after the impact:





This is what it looked like once it had collapsed.

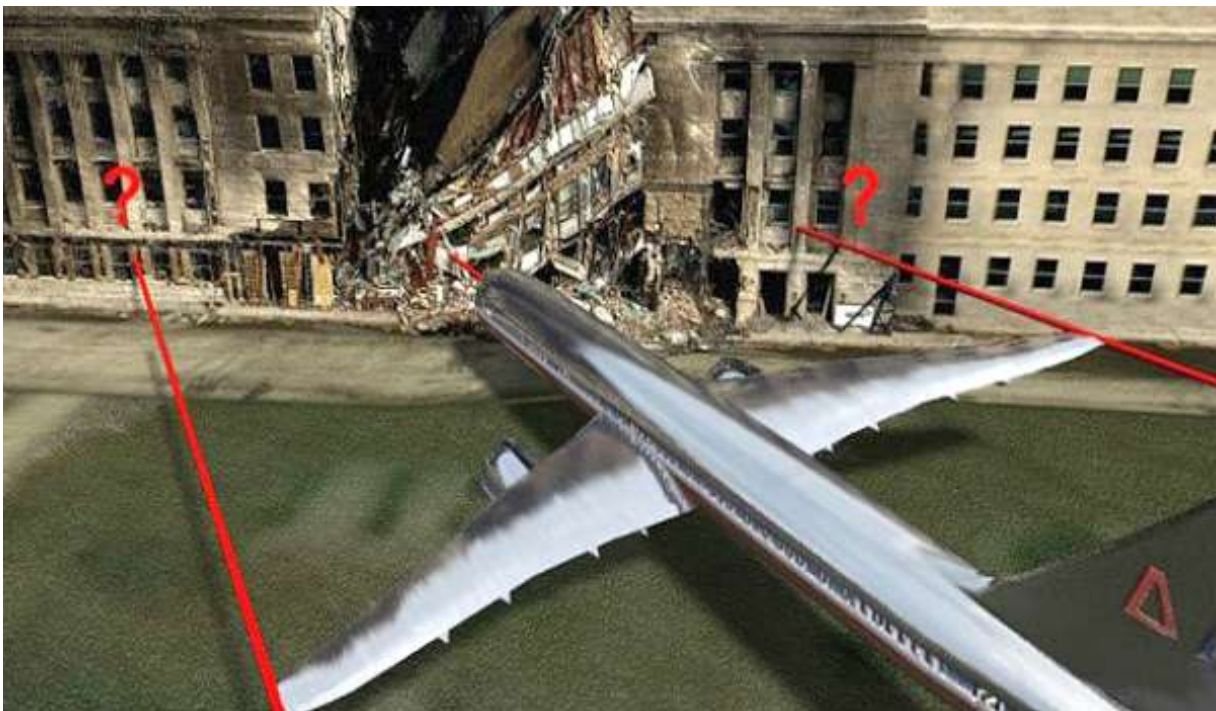

There is no real photo or video of the plane hitting the Pentagon even though the Pentagon must be one of the most surveilled buildings in the world.

The damage on the building that is supposedly due to the plane crash is not consistent with the size and form of the plane.

This document is however not an exposition of the technical evidence but of the symbolical and numerological evidence so let's get back to the numbers.

For the Pentagon attack they have chosen the following interpretation of the Masonic logo:

$$4-7 = 3$$

$$G = 7 \text{ (The seventh letter)}$$

$$9-0 = 9$$

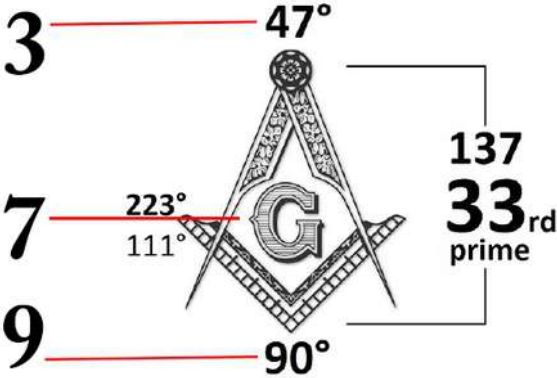

This gives a combination of the numbers 3, 7 and 9 to play around with.

The first reference is the point of time for the attack. It happened at 9:37am

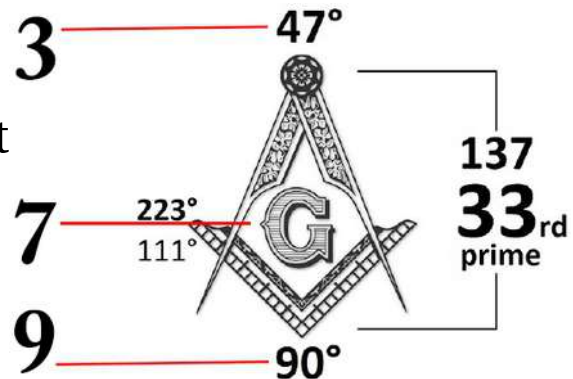

The second reference is that we had 9x3x7 dead. There were 64 persons on the plane and 125 in the Pentagon resulting in a total of 189 dead.



189 is 9x3x7



64 is 4x4x4

$$64 = 4 \times 4 \times 4$$

125 is 5x5x5.

$$\underline{125} = 5 \times 5 \times 5$$

$$189$$

The time and the number of casualties give the following constellation:

9x3x7 dead at **9:37am** as a plane carrying **4x4x4** crashes in and kills **5x5x5** in the **5-sided Pentagon**.

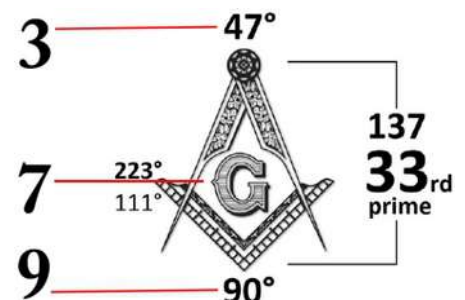

189 is a number with several connections to the logo.
 Besides being the product of $9 \times 3 \times 7$ it is also the 8th G in a continuous alphabet. (See appendix 1.2).

In the logo of NASA we had a 7-33 stars constellation.
 If we instead of 33 take 3^3 and multiply it with 7 we get 189.

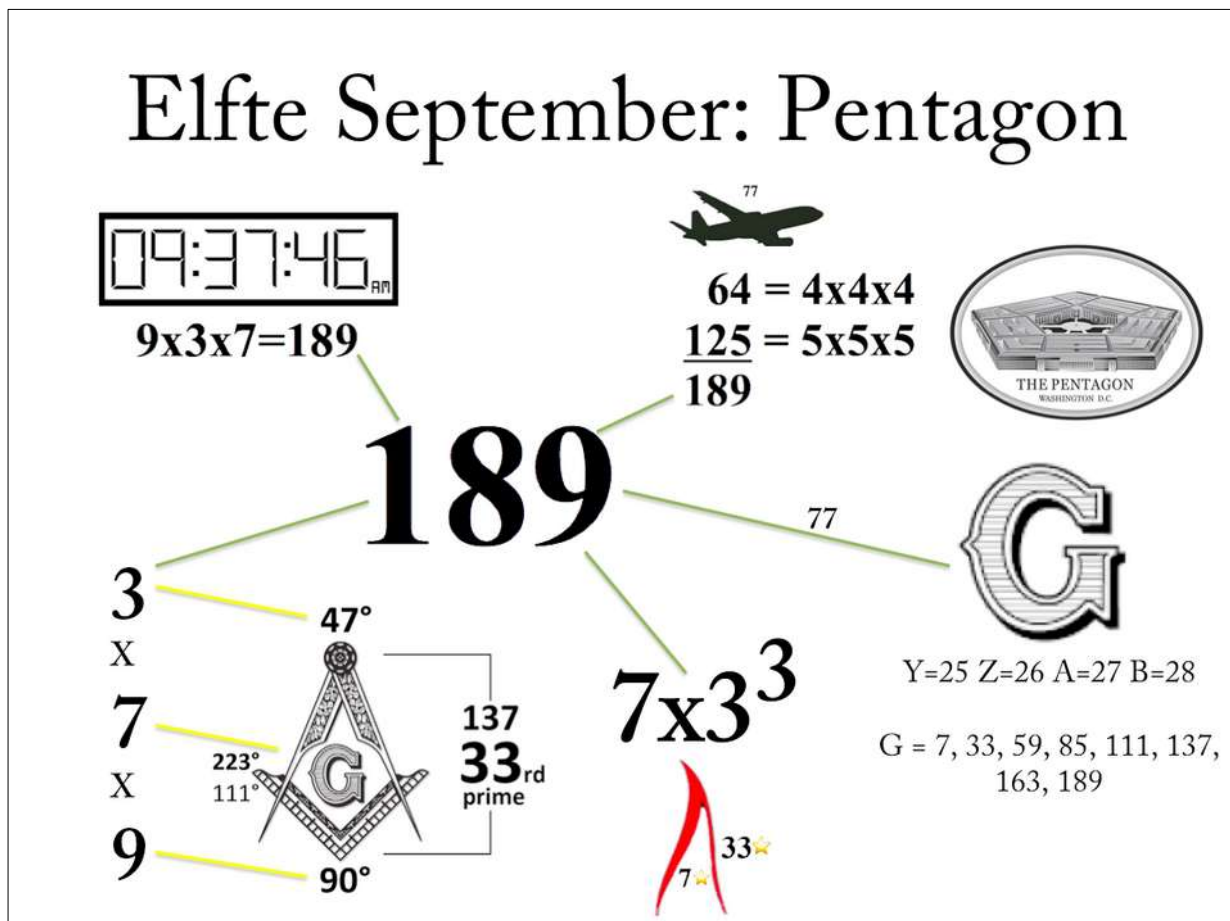

Could you have chosen better numbers?

Flight 93

Flight 93 crashed in the desert at 10:03:11. It carried a total of 44 persons consisting of 37 passengers and 7 crew.



We have 37 passengers for the compass and the square.

Compass = 28 (4x7)

Square = 9 (9+0)

We also have 7 crew for the G.

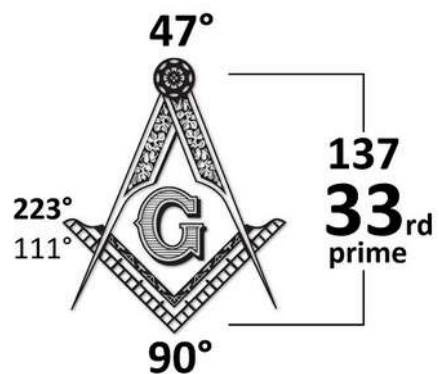

Total: $28 + 9 + 7 = 44$.

There is also another way to see it:

4 terrorists, 7 crew and 33 passengers giving 47 & 33.

The point of time will be explained later on. For now I will only mention that it is 77 minutes between the first attack as flight 11 crashes into the north tower and this crash.

Building 7

The last thing to happen on nine eleven was the collapse of building 7.



The collapse of building 7 was announced on the news already 20 minutes before it happened.

As we see from the screenshot from BBC's live broadcast from nine eleven it says that "The 47 storey Salomon Brothers building has collapsed" while the building still is visible in the background.

Building 7 was called the Salomon Brothers building and it was 47 storeys high.

Do you remember the temple of Solomon?

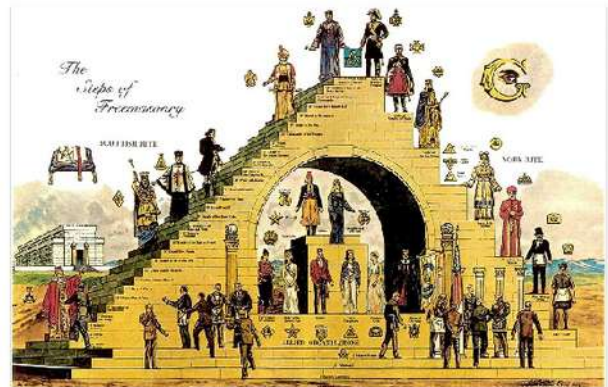

In front of the Temple of Solomon stood two pillars: Boaz and Jachin.

In front of the Salomon Brothers building stood two pillars: the twin towers.

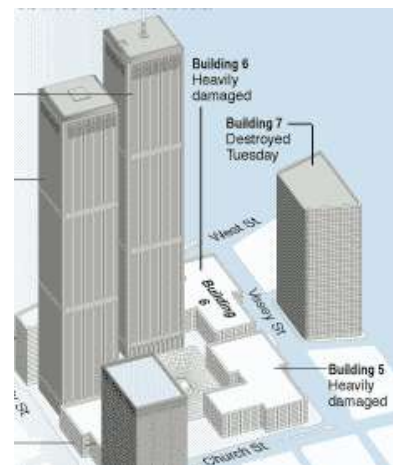

The ritual of nine eleven started with the pillars of the mind being hit and brought to the ground. It ended with the temple of the mind collapsing down.

(More about this in later chapters)



The official story tells that debris from the twin towers somehow caused violent fires in the basement of building 7 making it come down in what looks like a typical controlled demolition.

Building 7 started falling at 5:20:33.

52 for the York Rite.
13 degrees in 4
sections (13x4)

33 for the 33 degrees
of the Scottish Rite.

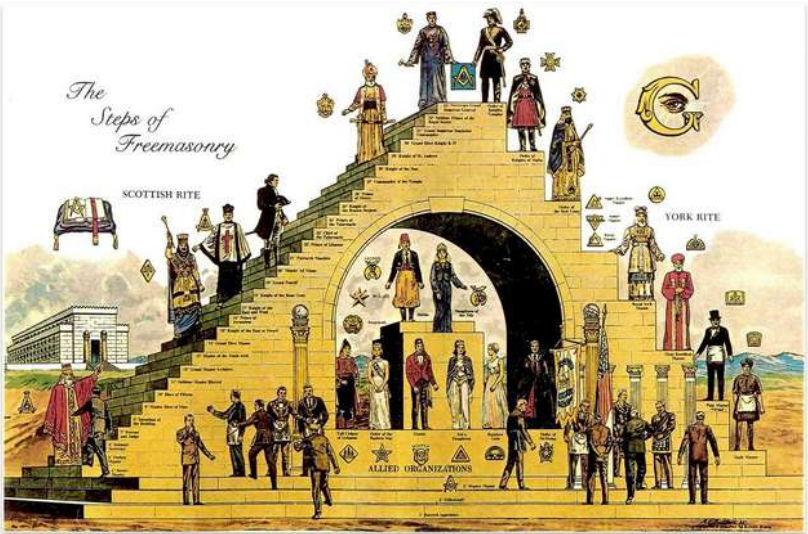

These numbers are not random. The total amount of crew on the four planes was 33. Add to it the 19 terrorists and we get 52 non civilians.

The number 52 occurs twice and both times in combination with 33 because on it's own it's without meaning.

There is a pattern and the pattern is built around one version of the Masonic logo.

This is the great discovery.

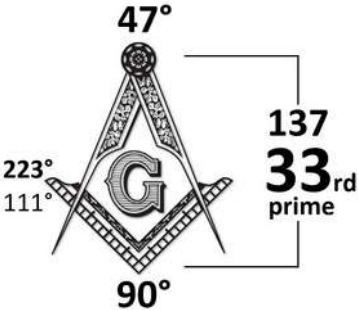

All those who already believe nine eleven was an inside job do so because of the technical and circumstantial evidence, not because of the numbers. These numbers and the numerological pattern still remain unknown to the conspiracy researchers of the world.

The exposure of this pattern and the numbers in nine eleven and other terror attacks will be the engine for spreading the solution of total transparency over government.

When the day comes we will all be aware of the conspiracy, we will have basic knowledge about consciousness and mind control, and we will know how to peacefully and intelligently organize our way into a world governed in truth.

Now that we understand the pattern and how it is used we can see if we also find it in other terror attacks, namely the three largest terror attacks in Europe.

However, to fully comprehend them we need more background knowledge. For this purpose we will only look at the dates, the times and the amount of dead and injured and how they relate to what we already know.

We will later on come back with more knowledge and look at nine eleven as well as the Europe attacks again.

Let's start with the third largest attack in Europe as it is very easy and straightforward to decode.

London 7/7

There was an attack in London that consisted of bombs being detonated on a metro train and on a bus.



The date of the attack was 7/7. This is of course a reference to the number 77 and to mind and body.



Location	London, England
Date	7 July 2005; 14 years ago 8:49–9:47 (UTC+1)
Target	Public aboard London Underground trains and a bus in Central London
Attack type	Suicide bombings
Weapons	IEDs
Deaths	56 (including the 4 bombers)
Injured	784
Perpetrators	Hasib Hussain Mohammad Sidique Khan Germaine Lindsay Shehzad Tanweer
Motive	Islamic terrorism

The attack started at 8:49 as bombs exploded on three metro wagons.

It started at 11 to 9.

The bus then exploded at 9.47.

The total number of dead was 56 or
9+47

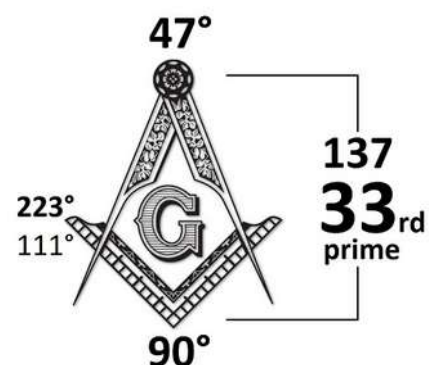

The most remarkable aspect of the “code” used in this attack is however the number of injured persons.

The number of injured is said to have been 784.

784 is a very creative but also precise reference to the compass and the square of the Masonic logo.

Let’s start by taking the 47 of the compass and making it 4x7. We then get 28.

Now instead of using the 90 of the square we use the square itself and take 28 squared. This gives us 784.

$$4 \times 7 \text{ squared} = 784$$

$$28 \times 28 = 784$$

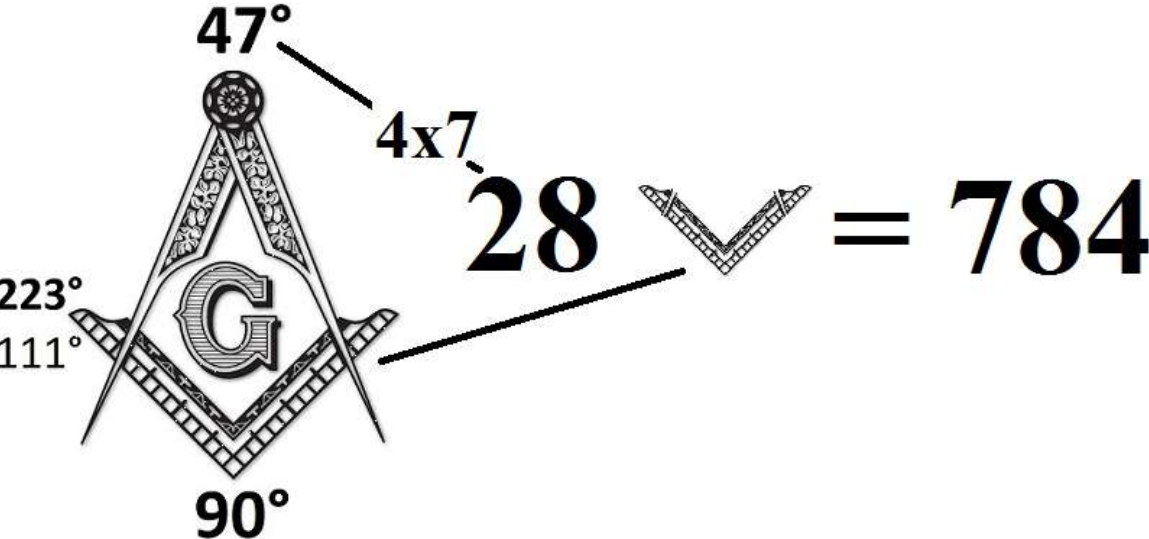

Madrid M-11

There are totally 40 stars in the logo of NASA.

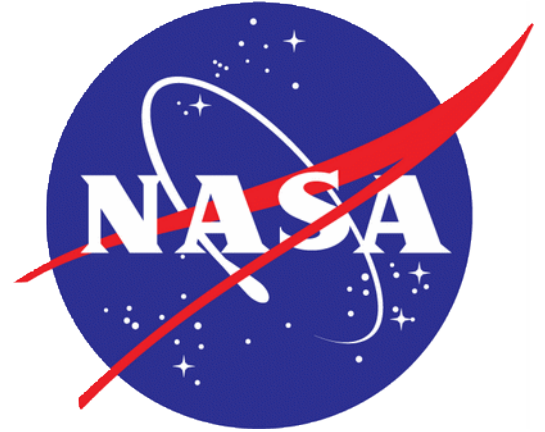

We have 7 inside the red vector and 33 outside.

These 33 are divided into 14 above and 19 below the red vector.

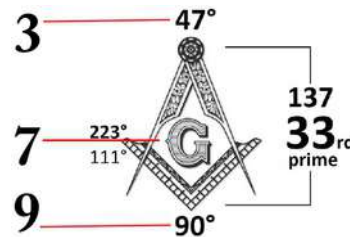

19 below because $3+7+9 = 19$

The 14 stars above the red vector are organised so that we have 3 inside the comet and 11 outside.

We have 3:11, just like the date of the Madrid attack

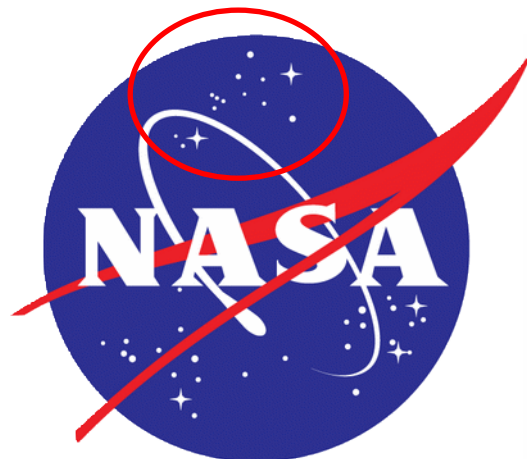

Flight 93 crashed at 10:03:11 on nine eleven.

One reason for this point of time being chosen is that it contains 3:11



In the London 7/7 attack three metro wagons were blown up. They were numbered 204-216-311.



311 because it is 3:11

216 because it is 6 x 6 x 6

204 to make the total 731 or 137 mirrored.

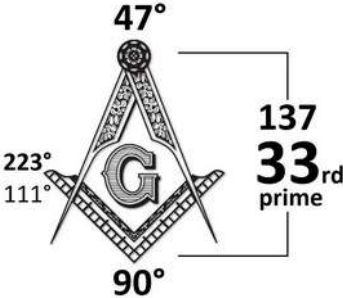

The largest terror attack in Europe happened on the 11th of March in Madrid, Spain.

The date of the attack is 3:11.

The primary number of freemasonry is the number 33. The number 33 can only be factorized in one way; that is 3x11.

3:11 is hence the factorization of 33.

33



3 x 11



311 is also the 64th prime number.

64 is the number of the cube.



A cube has (6) faces, each face is a square with (4) sides = $64 = 6$ faces, 4 sides

A square has 4 equal sides.

If we take 4 to the power of 3 we get $4 \times 4 \times 4$ or 64. This is a square brought to 3 dimensions: a cube.

The symbolism of the cube will, as so many other things, be explained later on. Now we focus on the numbers.

2004 Madrid train bombings

Part of the spillover of the Iraq War and Islamic terrorism in Europe

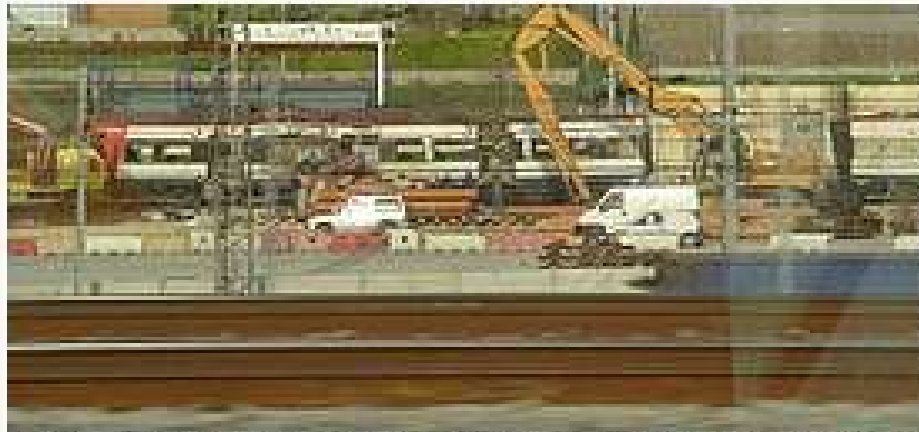

Remains of one of the trains, near Atocha station

Location	Madrid, Spain
Date	11 March 2004; 16 years ago 07:37 – 07:40 CET (UTC+01:00)
Target	Madrid commuter rail network, civilians
Attack type	Mass murder, time bombings, terrorism
Weapons	Goma-2 backpack bombs
Deaths	193
Injured	2,050 ^[1]
Perpetrators	Al-Qaeda in Iraq ^[2]
Motive	Opposition to Spanish participation in the Iraq War

The attack started at 7:37.

This is just like flight 93 carrying 7 crew and 37 passengers.

The 7 is for the G and the 37 is for the compass and the square.

$$7 = G$$

$$37 = (4 \times 7) + (9 + 0)$$

The attack ended at 7:40
which is 47 mirrored.

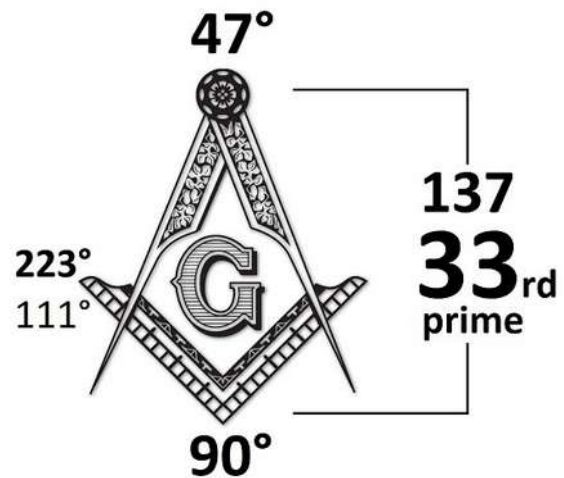

We have a total of 193 casualties.

193 is the 44th prime number.

$$37 + 7 = 44$$

$$(4 \times 7) + 7 + 9 = 44$$

The number of injured was 2050+.



2015 Paris Terror Attacks:

The attack in Paris started at 9:16 pm the evening of Friday the 13th of November and it ended at 0:58 am the 14th of November.

Besides happening on Friday the thirteenth, which has Masonic significance, this attack also happened on the day when there remained 47 days until the end of the year.

This was a very complicated event consisting of several different attacks around Paris. One theme of the attack is what the Freemasons call the 47th problem of Euclid

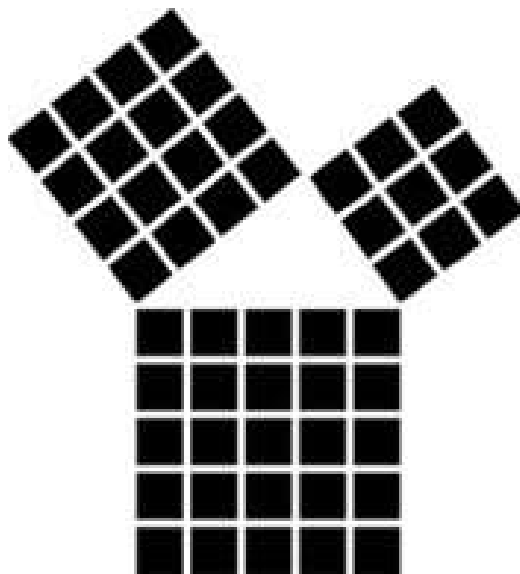

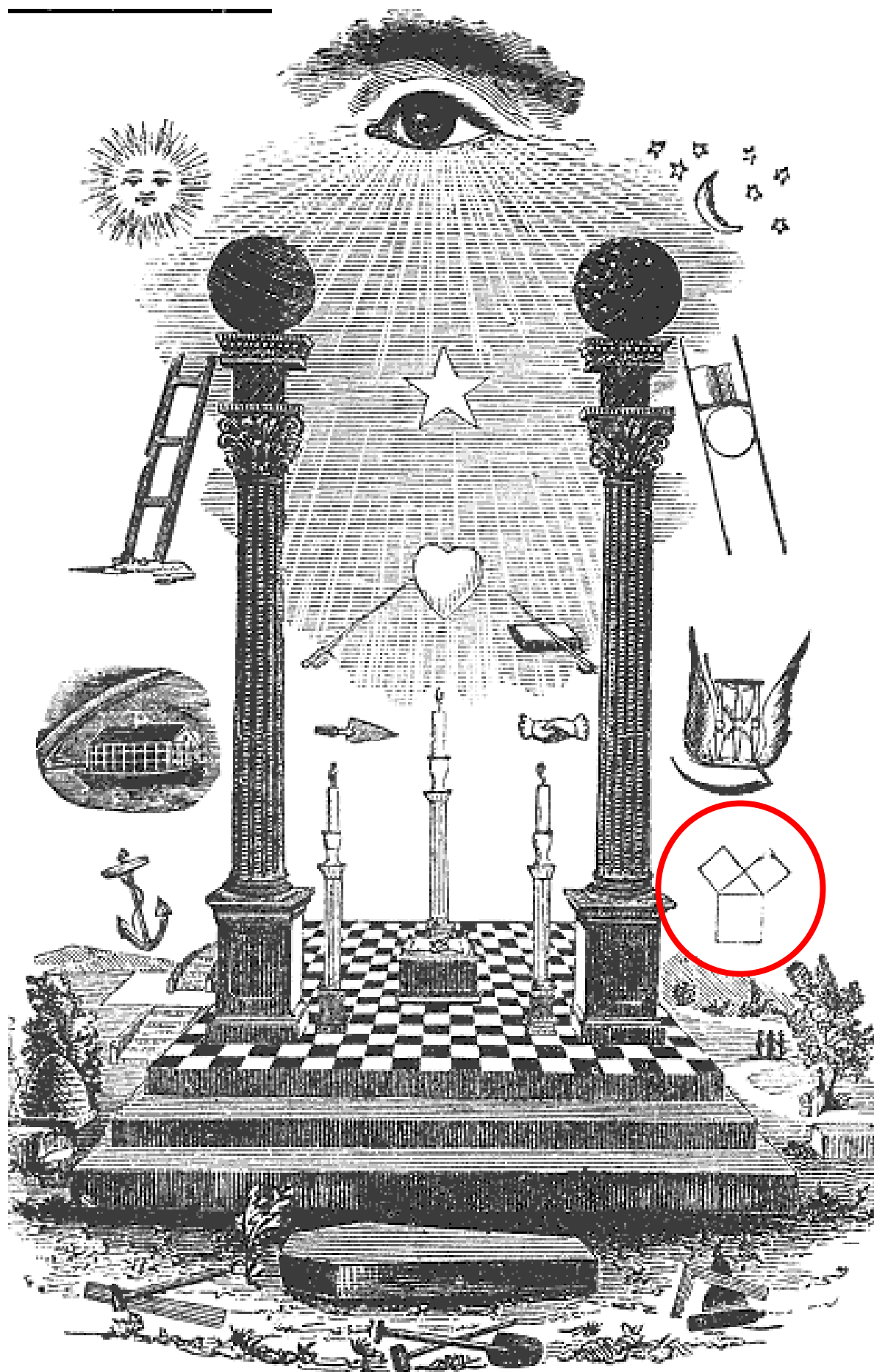

The 47th problem of Euclid is most probably a concept with a great amount of occult meaning and teaching associated to it.

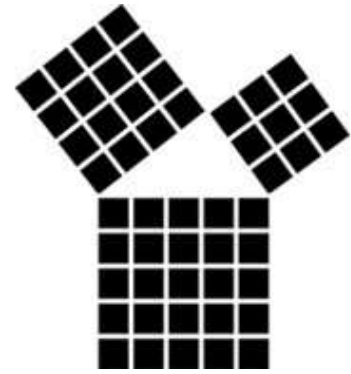

The public description can easily be found through a Google search.

The numbers associated with the 47th problem of Euclid are:

$$3 \times 3 + 4 \times 4 = 5 \times 5 \quad \text{or} \quad 9 + 16 = 25$$

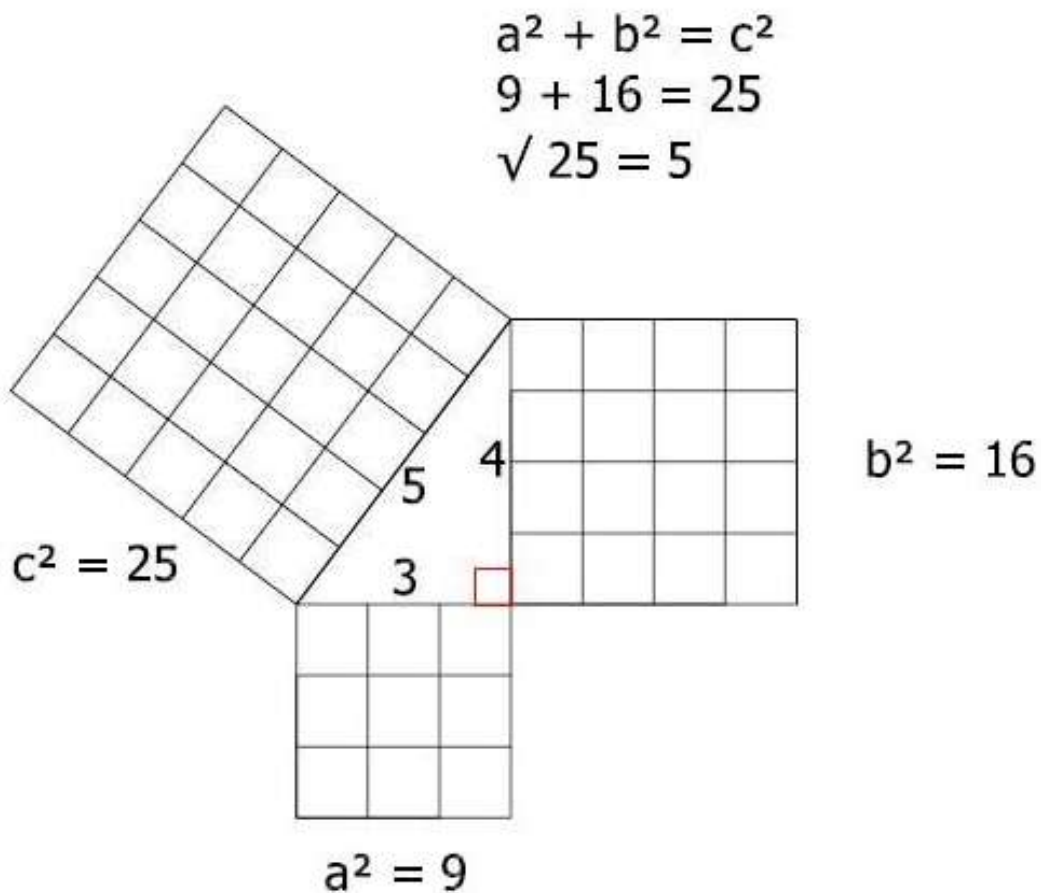

The attack in Paris started at 9:16 pm with the 'Stade de France' suicide bombings.

9:16 is 3x3 and 4x4.

The second suicide bombing happened at 9:19 pm

919 is the 157th prime number.

157 is 322 and the 37th prime

The shooting, which was the next event then started at 9:25 pm on Rue Bichat.

9:25 is 3x3 and 5x5, the completion of the 47th problem of Euclid.

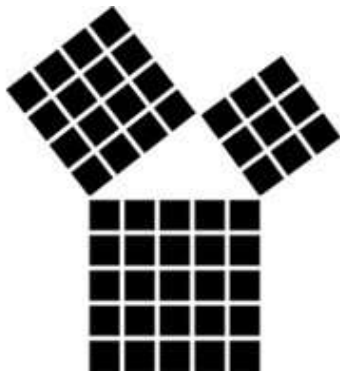

Timeline of attacks

13 November:

- 21:16^[note 1] – First suicide bombing near the *Stade de France*.^[14]
- 21:19^[note 1] – Second suicide bombing near the *Stade de France*.^[14]
- 21:25 – Shooting at the *rue Bichat*.^[14]
- 21:32 – Shooting at the *rue de la Fontaine-au-Roi*.^[14]
- 21:36 – Shooting at the *rue de Charonne*.^[14]
- 21:40 – Suicide bombing on *boulevard Voltaire*.^[14]
- 21:40 – Three men enter the Bataclan theatre and begin shooting.^[14]
- 21:53 – Third suicide bombing near the *Stade de France*.^[14]
- 22:00 – Hostages are taken at the Bataclan.^[53]

14 November:

- 00:20 – Security forces enter the Bataclan.^[14]
- 00:58 – French police end the siege on the Bataclan.^[53]

All times are CET (UTC+1).

The attack started at 9:16 pm on the 13th of November. This means that it started when there remained 47 days until the end of the year and 163 minutes until the end of the day.

163 is besides being the 7th G in a continuous alphabet also 322_7 . Changing the base to 7 can be understood as setting the context to be the G or the soul. (explained later)

163 is also the gematria for “Make America Great Again”.

The total amount of dead was 137

The amount of injured was initially reported to be 413 but has very recently been changed to 416 in some sources and Wikipedia pages.

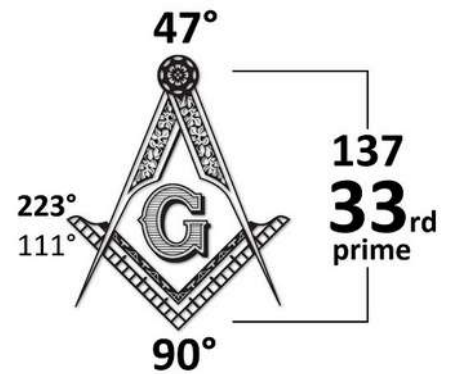

If we go with the initial 413 we get:

137 = 33rd prime for the Scottish rite:

413 = The 13 degrees in 4 sections of the York rite.

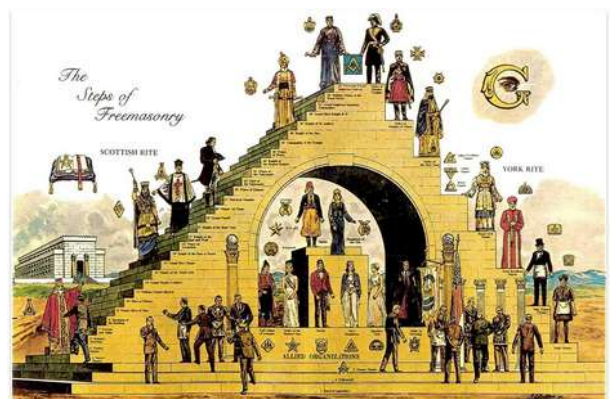



Ver todo

es.wikipedia.org › wiki › Atentados_de_Paris_de_novie... ▼

Atentados de París de noviembre de 2015 - Wikipedia, la ...

Heridos, **413**. Perpetrador(es). Bandera de Estado Islámico Estado Islámico; Salah Abdeslam. Motivación, Yihadismo. [editar datos en Wikidata]. Los atentados en **París** de noviembre de 2015 fueron varios ataques terroristas cometidos en ... «Paris attacks: Injured Irishman has surgery as NI people tell of 'panic' on ...

Tipo de ataque: Tiroteo, explosión, toma de r... **Fecha:** 13 - 14 de noviembre de 2015; 21:1...
Muertos: : 131 civiles ; 7 terroristas; **Heridos:** 413

en.wikipedia.org › wiki › Novemb... ▼ Traducir esta página

November 2015 Paris attacks - Wikipedia

The attackers killed 130 people, including 90 at the Bataclan theatre. Another 416 people were injured, ...

Injured: 413 (80–99 critically) **Deaths:** 137 (130 victims and 7 perpetrators)
Victims: Civilians **Location:** Paris and Saint-Denis, France

www.nytimes.com › World › Europe ▼ Traducir esta página

For Survivors of Paris Attacks, Mental Scars May Outlast Wounds

30 nov. 2015 — But the attackers also **wounded** more than three times that number — **413** people — who survived. Many are still struggling to recover from ...

13–14 November 2015	 Paris and Saint-Denis, France	November 2015 Paris attacks	A series of co-ordinated attacks began over about 35 minutes at six locations in central Paris. ^[52] The first shooting attack occurred in a restaurant and a bar in the 10th arrondissement of Paris. There was shooting and a bomb detonated at Bataclan theatre in the 11th arrondissement during a concert by the Eagles of Death Metal. Approximately 100 hostages were then taken and overall 89 were killed there. Other bombings took place outside the Stade de France stadium in the suburb of Saint-Denis during a football match between France and Germany. ^[62] Europol classified the attacks as jihadist terrorism. ^[52]	130 (+7 attackers)	413
---------------------------	--	-----------------------------------	---	-----------------------	-----

To conclude:

The attacks of nine eleven happened on the one day of the year that has the most connections to this version of the Masonic logo.

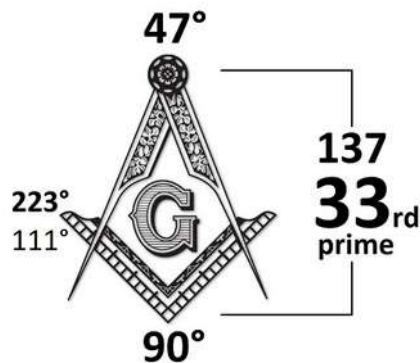

The attacks started in the 47th minute of the 9th hour as the north twin tower was hit.

The south tower was then hit at 09:03

The planes that hit the towers carried 9-11 crew and 137 passengers.

In the Pentagon attack 9x3x7 persons died at 9:37am as a flight carrying 4x4x4 crashed in and killed 5x5x5 in the 5-sided Pentagon.

In London the bus exploded at 9.47 making it a total of 47+9 dead and 4x7squared injured.

This numerological code is a new discovery and it has given us an irrefutable evidence of a conspiracy.

This evidence will be used to spread awareness of the conspiracy as well as a solution and a plan on how to achieve total transparency over all governmental activity.

We humans, as empathic, compassionate and intelligent beings have all the knowledge, technology and resources to turn this planet into a flourishing paradise of peace, love, happiness and abundance.

The first step is a one day event in which we organize according to a plan in order to randomly select those in charge of making government transparent.

That's how we break free from the present paradigm!

The next chapter describes that plan.

The third chapter then return to these four terror attacks and looks at it from a scientific perspective. The chapter will among other things try to answer the question: how big is the probability that any randomly chosen number is part of the pattern. How big is the pattern with other words. First to the solution of intelligent, peaceful revolution

Documentaries:

About nine eleven:

- Loose change 2nd edition. (Don't watch 3rd or final cut)
- Explosive evidence. It has been removed from YouTube but is hopefully retrievable here:
<https://watch.thewest.com.au/show/1025>
It's not the "experts speak" version
- 9 11 Trillions Follow The Money Documentary HD
- JFK to 911 Everything is a rich mans trick
- Incontrovertible – New 9/11 Documentary by Tony Rooke
- September 11 - - The new Pearl Harbor

Other documentaries:

- Zeitgeist Addendum
- Money as Debt – Revised Edition 2009
- All wars are bankers wars
- Power of the purse

Chapter 2: The solution

The solution is truth:

- Awareness of the current situation
- Knowledge about the self: Self-development
- Meaningful action: Purposeful organisation towards collectively obtaining the truth

The first chapter of this document makes the reader aware of the existence of a conspiracy and their use of symbols and numbers. It is the first step towards understanding the situation that we are currently in. Later chapters will help deepen that awareness and understanding.

This second chapter handles the collective organisational aspect of the solution. It describes the meaningful action through which we together structurally free ourselves from the influence of the conspiracy. We take control over our democratic institutions and make them open and transparent for all the people.

The third chapter is an introduction to the knowledge of the self. We will talk about some basic mechanisms of consciousness and how these are exploited to control us. The third chapter will help us both to understand ourselves as well as the mind control that is employed to keep us down.

The fourth chapter will once again look at the conspiracy and their use of numbers and symbols. We will go back to interpret the more ritualistic aspects of nine eleven and we will look at the numbers of the largest terror-attacks in Europe. Finally we will talk about Covid-19.

But now, to the organisational aspect of the solution:

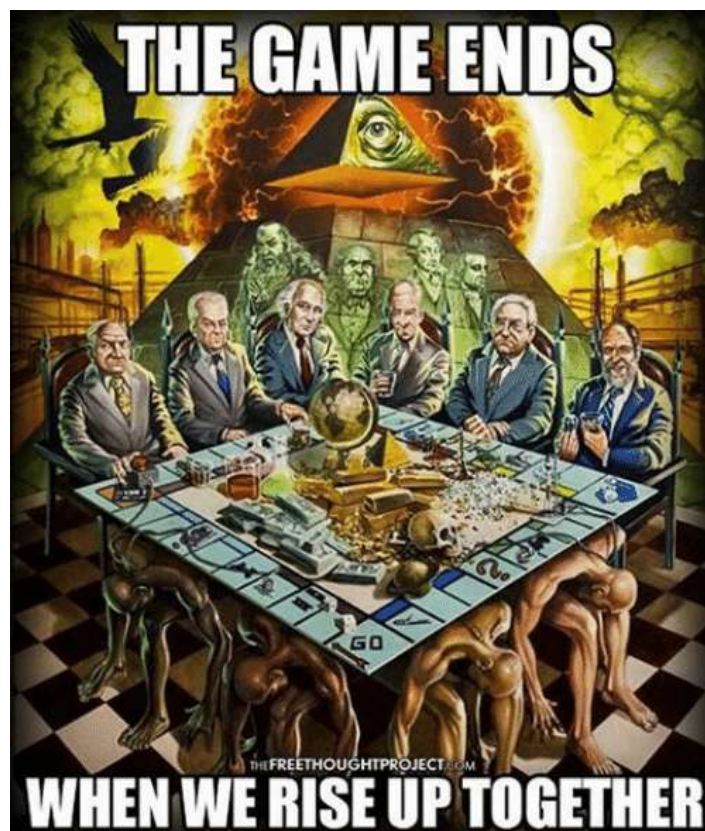

The situation that we are in is one that will not solve itself without us uniting and acting. Awareness of the conspiracy is not enough; we need to take control over the situation and direct development where we want it.

Unification is the key here. If we try to organize change that goes against the interest, values and beliefs of a part of the population then that part will mobilize against that change. The conspiracy will give support to the part of the population that is against the change and we will be trapped in conflict and opposition. We will be fighting each other rather than manifesting change.

Total governmental transparency is the only structural solution that we all can agree on and therefore the only structural change that can manifest.

Total transparency means that the people will know the full truth about everything that happens in government, that's all. It's politically, ideologically and religiously unbound. It does not create conflict or opposition among the people.

We let the present system continue as it is for now. Any attempt at structural, ideological or economical change

will lead to conflict and opposition. Truth and transparency is the first objective because it's only when we have the truth that we can know where to go next.

There exist many great ideologies and philosophies on how to best organize society and our coexistence but we cannot all agree on any of them.

The one and only solution that we can unite on is the truth, and it just happens to be that the truth is the exact opposite of the problem that are facing.

The conspiratorial pyramid is built through secrets and lies. We are controlled through secrets, lies and hidden manipulation. Darkness is where the conspiracy lives and acts, the light of truth leaves no room for them. It creates conditions that greatly favour those who truly wish to serve and work in the interest of the people.



Transparency allows for those who truly wish to serve the people to prove it. All their work will be visible to us. We will see what meetings they attend and how they behave on those meetings. We will see the documents and files on their computers, read their mails and listen to their phone calls. We will see the passion with which they fight to make the world better and all their actions will make sense to us.

Those who truly wish to serve the people will in turn be protected from attempts at corruption, blackmailing and extortion as any such attempt would be publicly known instantaneously as everything is visible for the people.

- 1 The situation will not solve itself. We have to come together, unite and act.
- 2 Without uniting we cannot manifest change as part of the population will mobilize against that change and we will spend all energy and time arguing and fighting each other.
- 3 Total governmental transparency is the one change that can be accepted by an overwhelmingly large majority of the population. Transparency is also the solution as it creates conditions that are diametrically opposite of the conditions under which the conspiracy operates.

How to make government transparent:

Government will be made totally transparent through the establishment of the system and structure which makes it transparent.

Exactly what this structure of transparency will look like depends on the local conditions. The technical aspect of building the system of transparency is relatively easy as we have already been building similar systems for a long time. We know how to broadcast, live stream and share files. Most of the infrastructure is already in place.

Building the system is technically easy. The important factor is to assure that those who build it have the intention of doing it correctly.

The crucial factor when it comes to building the system of transparency is the intention of those who build it.

We cannot trust the present government or any other established hierarchy to build it; neither can we all agree on who to trust.

The solution is therefore to have an event in which we randomly select, from among ourselves, those who will build the system of total transparency.

We make government transparent by organizing an event in which we randomly select those who will make government transparent.

Those who get randomly selected can then choose to take the task or to delegate it to someone they know personally, trust full and consider competent for the task.

The good hearted people who truly want a world of peace, happiness, abundance, love and truth outnumber those who want a world of fear and control.

We outnumber the conspiracy beyond comparison. They might have the knowledge, the resources and the organizational advantage but we have the numbers.

Random selection of those who will build the system of transparency is the way we take advantage of the numbers.

By going random we make it close to impossible that even one of their agents get randomly selected.

We make government transparent by organizing an event in which we randomly select those who will make government transparent.

This event of random selection is a self-organizing lottery that only requires one day of universal participation. For that most people won't even have to leave the street that they live on.

This one day is when we with full knowledge of the present situation, take over control in a peaceful way.

We mobilize to collectively manifest without asking for permission, we do so because it is absolutely necessary and we do so in a responsible and intelligent way.

This one day event of randomly selecting those who will make government transparent will take place in a context of universal awareness of the conspiracy.

We will all be aware of the existence and methods of the conspiracy. We will know that those at the top of the present governments are not working in our interest but are actually part of a scheme to control us.

We will understand the corrupting force of power and know how to handle it. How darkness is the environment in which power corrupts while transparency is the antidote.

When the day comes we will understand that we have to watch government. The people are big brother over government, not the other way around.



We have the right to know the full truth about the decisions that are taken in our names and that determine the condition for how we can live our lives.

We will claim and manifest that right through an event in which we randomly select those in charge of making government transparent.

We will do so collectively with a belief in a new world of truth and love. We act in love with the belief that something better is possible. We dare to believe, to hope and to act on that hope, so we break free from the chains of fear and open up to love.

As the day approaches every person that you see on the street will be a brother or a sister that you share an objective with. You are united by the same quest and the same plan on how to manifest truth and love on Earth.

The fractal structure:

The random selection process is a fractal dynamic.

A fractal is when the parts of the whole are identical to the whole but on a smaller scale.

The most basic example of a fractal structure is probably a cube made up out of 8 smaller cubes.

Each part of the structure, being a cube, is in shape identical to the whole structure, also being a cube.



Now let's imagine that each small cube is made up out of 8 smaller cubes, and that if we zoom in on those smaller cubes we see that they in turn are also made up of 8 even smaller cubes each, and so on.

That's the basic idea of a fractal structure.

The fractal dynamic:



A fractal dynamic is a dynamic that is self-similar throughout scale.

One example of a fractal dynamic is the playoff structure to many sports championships.

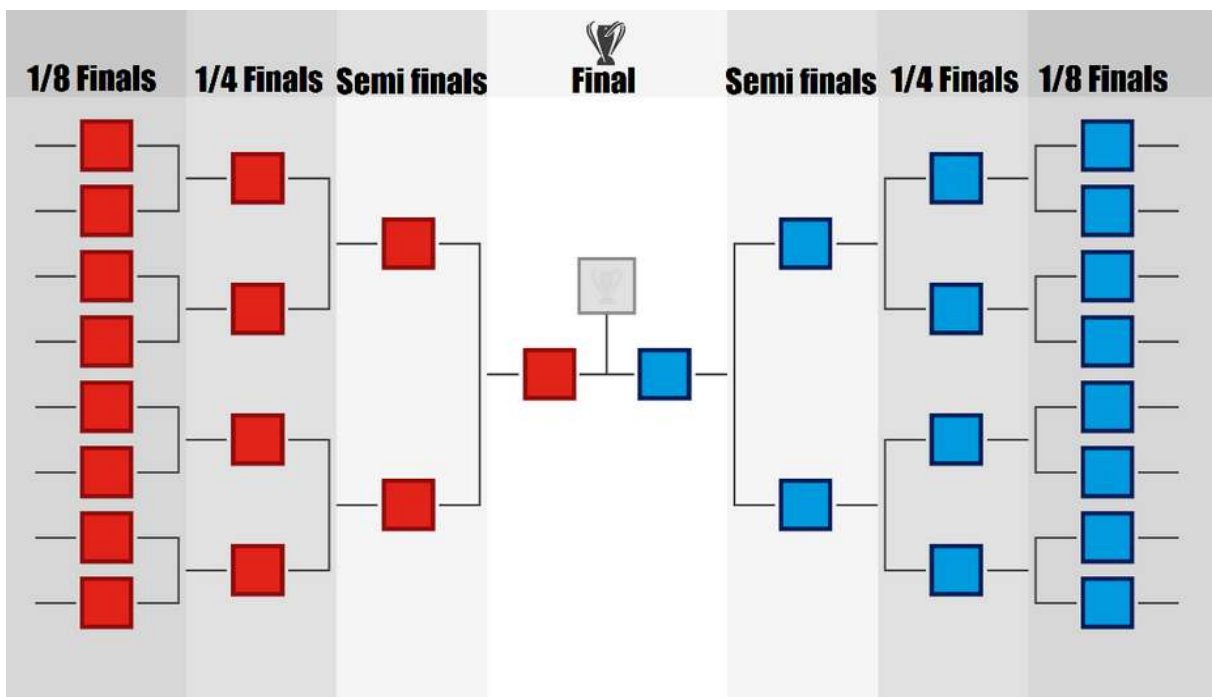

Here the same dynamic can be used with 2, 4, 8, 16, 32, 64, 128 or more teams. The same dynamic structure can be applied regardless of the amount of participants.

The random selection process is designed as a fractal dynamic because a fractal dynamic works the same regardless of the amount of participants.

This means that the same fractal dynamic can be applied in places with a few thousand inhabitants just the same way as in metropolises with millions of inhabitants.

The random selection process is designed as a fractal dynamic to make it applicable in all the different contexts globally.



Each small circle in the figure above is made up of six lines.



We will organize into groups of six.

If we add six small circles together we get a medium sized circle consisting of six small circles.

We will organize into groups of six. The winner in each group of six will then proceed to form a new circle together with the winners from other group.



If we add six medium sized circles together we get a large circle consisting of six medium sized circles, made up of six small circles each.

Each group of six winners will generate a new winner that forms a new group together with other participants who have also won their first initial group and then the group of winners.

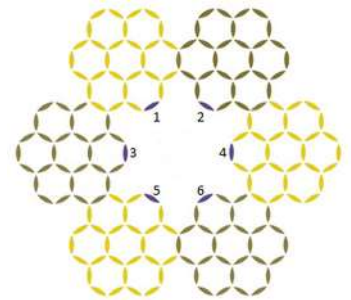

I think you get the basic idea.

Exactly how, when and where we will do this is described a few pages down. As this plan will spread together with the evidence of a conspiracy, it will enable us to coordinate towards a common goal without having to rely on leaders or build hierarchies. We have a full, self-organizing plan on how to do this. It cannot be infiltrated, threatened, corrupted or killed.

Levels of government and citizens committees



FEDERAL
PARLIAMENT

STATE/TERRITORY
PARLIAMENTS

LOCAL
COUNCILS



The governments of most countries are divided into different levels. The most common model is that of a national or federal government, regional governments and local governments.

We will select one group of people to constitute a citizens committee for making the local government transparent, another citizens committee for the regional government and yet another one for the national.

This means that we all participate in the “lottery” for three different citizens committees:

- 1 The committee that will make the national or federal government transparent,
- 2 the committee that will make the regional government transparent and
- 3 the committee that will make your local government transparent.



These lotteries will occur simultaneously.

If your country has a different structure of governmental levels then adjust the random selection process to match that structure. How to do this will become obvious once the dynamic of the random selection process is understood.

Execution of the random selection process:

The random selection process works as follows:

We start by meeting up with those who live on the same street as we do and together organizing ourselves into groups with six participants each.

There might be some groups with 5 or 7 if the total amount of participants on your street is not evenly dividable by six.



We will use a dice as an instrument of randomness.

Start with the lottery for the committee that will make the local government transparent.



Take turns hitting the dice. The one who gets the highest number wins and proceeds to the next level of the lottery. If two or more participants both have the highest number then they will hit the dice again to determine the winner.



Stay in the same group and repeat the same procedure for the regional government lottery and for the national government lottery.



This means that each group of six will generate one participant that proceeds to the next level in the lottery for a place in the citizens committee that will make the local government transparent, one participant for the regional government committee and one for the national.

This does not have to be different persons. If the same participant would happen to win the lottery for more than one level of government then he or she will proceed in those lotteries.

Once all the groups are done and everybody has participated on the first level we move on to the second level.

Everybody who progressed to the second level of the lottery for the local government will once again organize into groups of six. They will hit the dice and determine who wins the second level and proceeds to the third level.



The same procedure is then repeated for each level of government, (e.g. regional and national).



The first stage of the random selection process is together with those who live on the same street as you do.

The first stage is continued until you reach a level of the lottery at which there are less than ten participants left.



The idea is to continue the lottery on your street for as long as there are enough participants left to form new groups of six or several groups of 5 or 7.

If there are ten participants left on a certain level of the lottery then they can form two groups of five each, hit the dice and generate two participants on the next level.

If there are nine or less participants left on a certain level of the lottery then it's no longer possible to form new groups with 5, 6 or 7 participants each.

The first stage of the random selection process is together with those who live on the same street as you do and it ends when you reach a level of the lottery at which it is no longer possible to continue because there are not enough participants to form new groups.

Those who are still in the lottery will now proceed to the next stage.

The next stage of the random selection process is at the centre of the zip-code in which you live.

Everybody from your street who progressed to this second stage will now play together with participants that have progressed from their respective streets in the same zip-code.

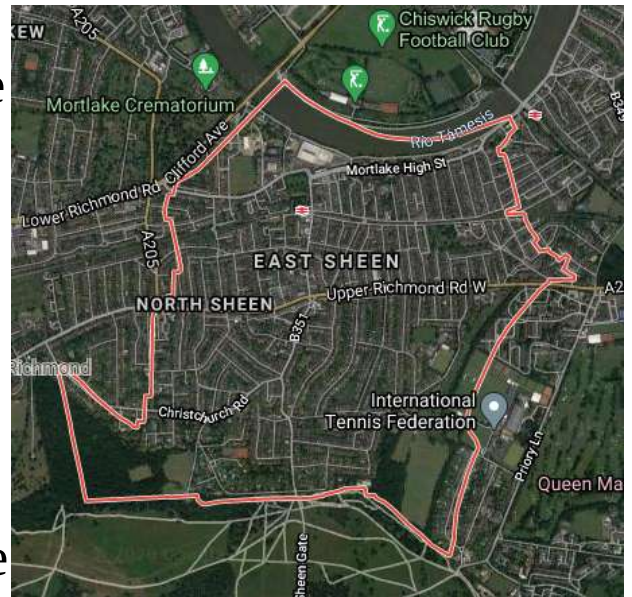

Start with those at the lowest level of the lottery for the local government. Let them organize into groups of six just the same way as in the first stage on your street.

Continue the lottery until there are less than ten participants left the same way as in the first stage.

The same procedure is then repeated for the regional and national government committees.

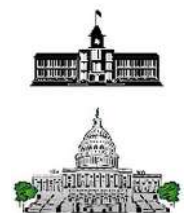

The different lotteries might also be held simultaneously if none of the participants are in more than one lottery.

The third stage is at the centre of the area that you live in. The procedure is exactly the same as in the centre of your zip-code.



Stages 1-4:



1. Your street



2. Centre of zip-code

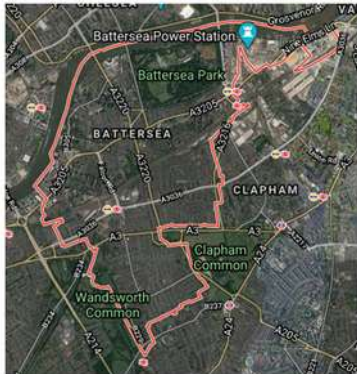

3. Centre of local area



4. Outside local government

The fourth stage is outside the main building of your local government. This is where we finally select those who will serve in the committee that will make the local government transparent.



As there are participants coming in from many different areas with different amount of population the participants will be on different levels of the lottery.

A highly populated area with six times the population of another smaller area will be one level ahead of the smaller area.

We start the fourth stage by bringing everyone up to the same level of the lottery. This is simply done by those with the lowest level organising themselves into groups of six as usual.

Those who proceed from the lowest level will then “play” with those who are already on the next level.

And so it continues until we reach the level held by the participant with the highest level.



In this illustration we have 10 participants on the lowest level, 14 on the level above that and 12 on the highest level.

The 10 participants on the lowest level will first organize into two groups of 5 and generate two winners who proceed to the next level.

These two winners join those 14 participants who are already on the next level. They together form 3 groups and generate three winners who proceed to the next level, which happens to be the highest.

The result is a situation in which we have 15 participants all on the same level of the lottery.

If it would happen to be the case that there are only four or less participants left at the lowest level of the lottery, then we have to use “dummies”.

A dummy is a non-participating person who joins the game and plays, but does not proceed to the next level would he or she win.

Let's for example say that we count the participants outside the local government and there are:

- 3 participants on level 3,
- 24 participants on level 4 and
- 7 participants on level 5.

Those three participants who are about to play on the third level cannot form a group of 5, 6 or 7. If they make a group of only 3 they will have twice as high possibility of reaching level 4 as the other participants had as they are only three while the others were six in their groups.

So, in this case we take use of three dummies to form a group of six with 3 participants and 3 dummies.



If any of the participants wins then they progress to the next level. If any of the dummies win then no one progresses.

So, we start this stage of the random selection process by bringing everyone who is still in the lotteries up to the same level just as already described.



The three different lotteries (local, regional, national) have so far been played the same way. This is however the stage at which those who will serve in the committee that will make the local government transparent will be selected.

Those who are still in the lottery for the regional and national government committees will repeat the procedure from the previous stage.

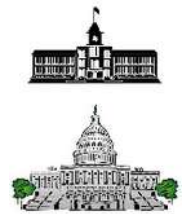

Those still in the lottery for the local government committee will, now that all participants are on the same level, organize with the aim of generating a group consisting of 9-12 participants to form the committee



How to organize to generate a group of 9-12 to form a committee:

Participants left	Form groups of	Number of groups	Dummies	Number of participants that proceed from each group	Size of committee
13	13	1		12	12
14	7	2		6	12
15	5	3		4	12
16	4	4		3	12
17	6	3	1	4	11-12
18	6	3		4	12
19	10	2	1	6	11-12
20	5	4		3	12
21	7	3		4	12
22	2	11		1	11
23	12	2	1	6	11-12
24	6	4		3	12
25	5	5		2	10
26	13	2		6	12
27	9	3		4	12
28	7	4		3	12
29	5	6	1	2	11-12
30	6	5		2	10
31	8	4	1	3	12
32	8	4		3	12
33	3	11		1	11
34	6	6	2	2	10-12
35	7	5		2	10
36	6	6		2	12
37	13	3	2	4	10-12
38	10	4	2	3	10-12
39	10	4	1	3	11-12
40	2	10		1	10
41	7	6	1	2	11-12
42	7	6		2	12
43	4	11	1	1	10-11
44	4	11		1	11
45	9	5		2	10
46	12	4	2	3	10-12
47	12	4	1	3	11-12
48	4	12		1	12
49	5	10	1	1	9-10
50	5	10		1	10
51	13	4	1	3	11-12
52	13	4		3	12

In our example we have 15 participants left. According to the table they are to form 3 groups with 5 participants in each. Four participants will proceed from each group to form a committee consisting of 12 citizens.

Those selected into the committee for the local government will now choose whether to take that position or to delegate it to someone they know personally, trust fully and consider competent for the task.

Those who finally form the committee will, after the best of their knowledge and ability, administrate the construction and instalment of the system of transparency.

They are of course free to bring in the knowledge and the labour needed from outside, preferably using people they personally know as far as possible.





The fifth stage of the random selection process is only for the committees that will make the regional and national governments transparent as those for the local government committee have already been selected.

This stage is outside the main building of the regional government.

Here we select those who will serve in the committee for the regional government just the same way we did for the local government.



Those in the lottery for the national government will repeat the procedure from previous stages.





The last stage of the random selection process is held outside the main building of the national government. Here the committee for the national government will be selected in the same way as for the other levels of government.

As the national government will have buildings throughout the nation, the committee for the national government will cooperate with local committees in order to make those buildings transparent.



The whole random selection process will be recorded by the participants using their smart phones or other devices with video recording capacity.

This will generate a record of the whole event that can be used to assure that no cheating took place.

All those who win a place in a committee will already carry with them a video of the whole process. They will have a record of their way from the street they live on and into the committee.

Cheating will be impossible.

The work of the committees will also be made transparent. It means that the building of the system of transparency will itself be live streamed, recorded and made publicly available.



We will do this once and for all. We will do everything that is necessary to absolutely guarantee a government that truly works in the interest of the people and that the people know the full truth.

This random selection process is to be executed all over the world on the same day.

This is for all of humanity. We do this together, all of us, once and for all.



The date chosen for when humanity steps out of the darkness and moves into the light of truth is the 22nd of February 2022. The significance of this date, in its fullness, can only be explained once we have a basic understanding of human consciousness. We will get back to the meaning of the date in later chapters. For now, it will be introduced as the “Palindrome of Three Hearts”.

A palindrome is a word or a number that is the same read from front to back as from back to front, for example: kayak, level, madam, radar, revival...

The date chosen can be written as 22.02.2022. It is then a palindrome as it is the same back to front as front to back.

In the date we have three sets of 22. If we turn the first 2 in each of the 22's, then we get three  or three hearts.



The Palindrome of Three Hearts is the day we come together, turn development and create world of truth.

Time table:

The first stage together with those who live on the same street as you do starts at 12:00

The second stage, at the centre of your zip-code, is at 14:00

The third stage in the centre of the area you live in will start at 17:00

The fourth stage outside the local government is starts at 20:00

The fifth stage, outside the regional government, is held the following day at 16:00

The sixth and final stage outside the main building of the national or federal government is held on Thursday the 24th of February at 18:00.

How to get there:

All that is needed for this whole plan to manifest is for this document to spread. That's it.

The first chapter will bring universal awareness of the conspiracy and the solution of total transparency will be obvious solution once the situation is understood well enough.

The only contribution asked from those who read this is to help it spread. It's the only contribution asked because it is enough. The rest will resonate into being once enough people are aware.

Spreading this material might be hard for the first one in a group of friends due to the stigmatization of the topic but once there are two or three who do it together they will have support from each other.

If two friends come to you and say that they have seen convincing evidence of a conspiracy and want your opinion, would you read it?

What if a group of five friends came?

The first one has to be brave. That's how we get there. That's how we take control over the development of artificial intelligence and make it a fully transparent process. The first one has to be brave.

One important aspect to be understood is that the numbers in the first chapter – the evidence – is convincing if you have a basic understanding of what freemasonry is and that they use symbols and numbers as a form of discrete communication.

However, if you don't even know that masonry exists then the numbers won't make much sense at all.

Confusion will be the first impression and they will be less open.



The first chapter of this document presents the evidence in a logical sequence. The best strategy will in most cases be to talk about an evidence rather than numbers and then ask the person to read the first chapter to get their opinion on it.

Growth models:

There are different models for how fast the document can spread.

If we imagine a scenario in which it takes a person exactly one week to spread this document in such a way that one more person starts to spread it, then the number of people who are aware and spreading will double every week.

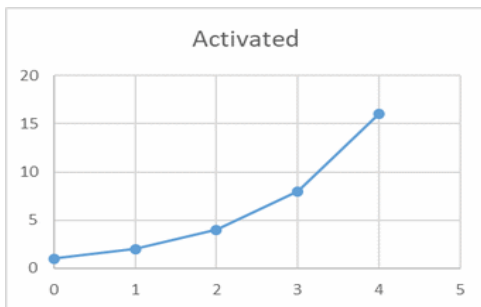

One person will become 32 persons in five weeks.

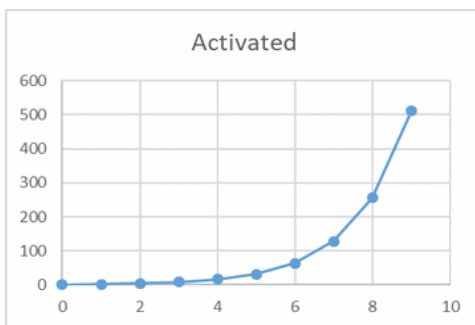

Those 32 will become 1024 in another five weeks.

Ten weeks from that the 1'024 have become 1'000'000.

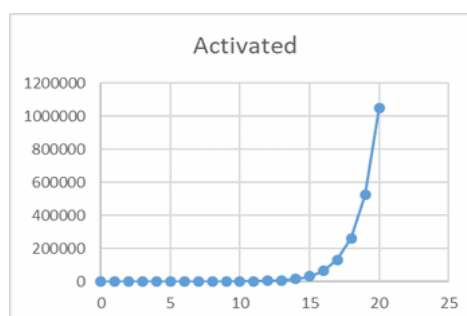

Another ten weeks, that is totally 30 weeks from the start and the first person has now made aware and activated 1'000'000'000 persons.

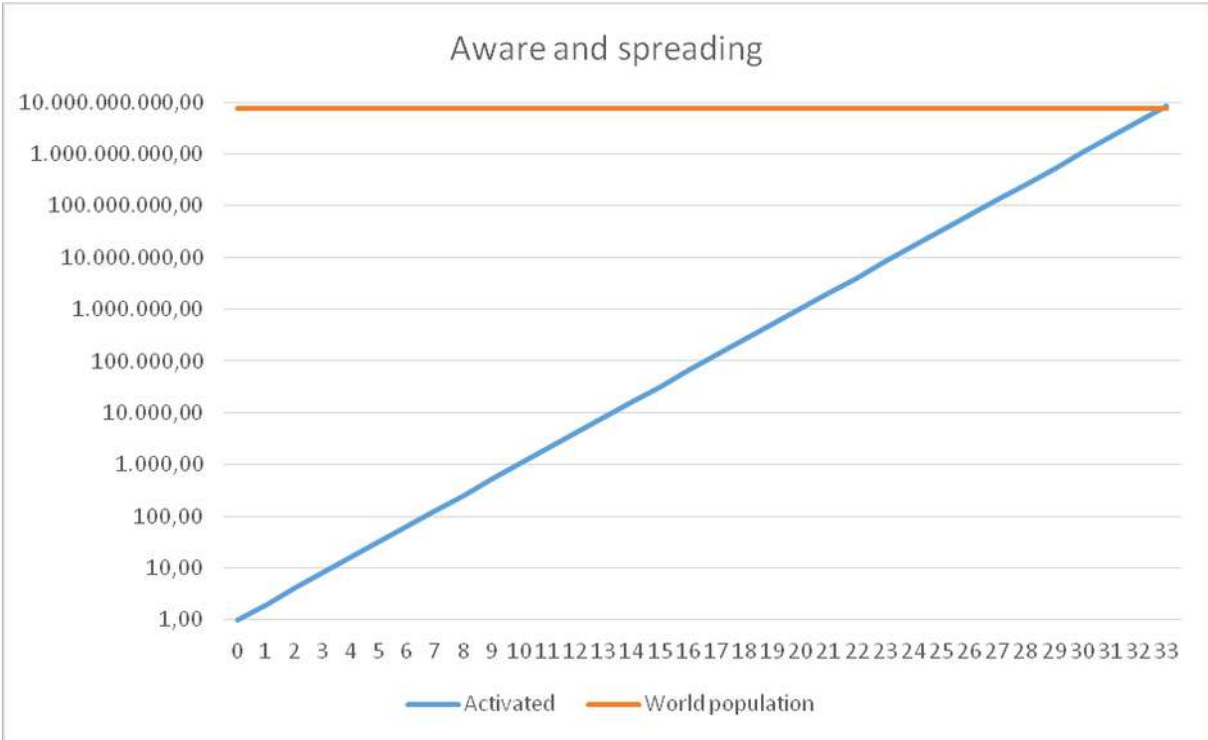
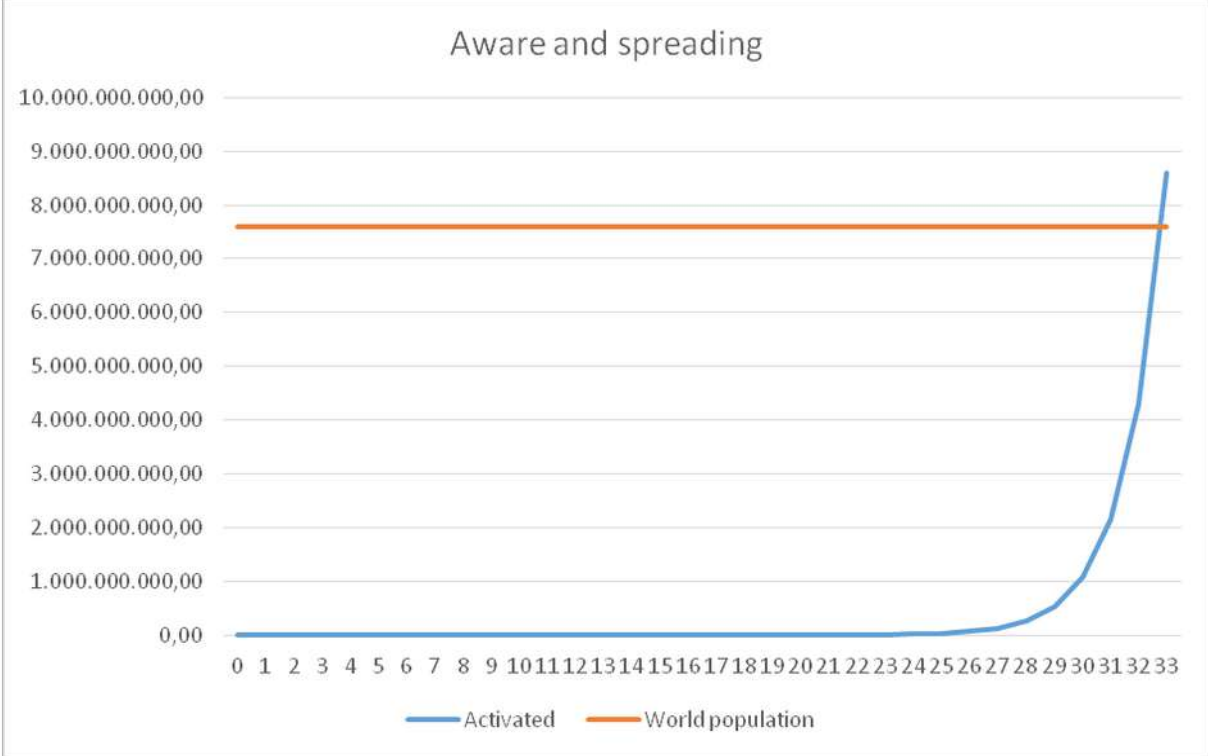

This document contains everything that is needed for humanity to peacefully move into the Era of Truth.

What it all comes down to is if you found the evidence convincing and if you agree with the objective of total governmental transparency as a solution to unite behind.

The evidence needs to spread because we need to know the truth about the present situation. Our behaviour and our actions need to be based in a world view that corresponds with reality for that behaviour and those actions to generate the outcome that we desire.

The problems that we experience as a society as well as in our individual lives are to the major part nothing more than symptoms of the mind control employed by the conspiracy.

To solve these problems, we need to solve the underlying cause, and to solve the underlying cause we need to know what it is. We need to understand the situation and for that we need the truth!

If we base our actions on false information, then we don't get the outcome that we expect. If we live in a world view that does not correspond with reality, then our actions will not generate the outcome that we seek.

To solve our problems, we need to understand what generates them and then take meaningful action directed as deep at the roots of the underlying cause as possible.

In the present situation in which a sinister conspiracy wages a war on our consciousness that meaningful action takes two expressions: one internal individual and one external collective.

The external collective is to bring truth to the institutions through which we organize our coexistence.

The internal individual is to bring truth into ourselves and our lives. This starts with an understanding of the self and the mind; an understanding of who we truly are.

The fourth chapter is an introduction to hidden knowledge of the mind. It gives some basic tools for understanding how we work and for recognizing as well as protecting oneself from the mind control employed by the conspiracy.

Chapter 3: A scientific discussion of the evidence:

The question is, can all numbers be connected to the pattern? How big is the chance that any randomly chosen number or date is part of the pattern?

If 80% of all numbers are part of the pattern then the probability of randomly getting 5 out of 5 numbers that fit the pattern is 32,8%

If the pattern consists of 20 % of all the numbers, then the probability of randomly getting 5 out of 5 is 0,032%.

32,8% is 1 in 3 while 0,032% is 1 in 3125.

What if we would have 10 or 15 numbers instead of just 5?

What is one of the numbers does not fit the pattern while the rest do, what are the probabilities then?

This chapter will essentially try to answer one question: how big is the probability that the observed pattern is the result of chance?

We will make an attempt at answering that question by first defining the pattern. This means that we set a certain rules and conditions for what the pattern is.

Using these rules and conditions we than make a table that shows all the numbers within a certain range high-marking those that connect to the pattern.

21	22	23	24	25	26	27*	28	29	30	31	32	33*	34	35	36	37	38	39	40
41	42	43	44	45	46	47	48	49	50	51	52	53	54	55	56	57	58	59	60
61	62	63	64	65	66	67	68	69	70	71	72	73	74	75	76	77	78	79	80
81	82	83	84	85	86	87	88	89	90	91	92	93	94	95	96	97	98	99	100
101	102	103	104	105	106	107	108	109	110	111*	112	113	114	115	116	117	118	119	120
121	122	123	124	125	126	127	128	129	130	131	132	133	134	135	136	137**	138	139	140
141	142	143	144	145	146	147	148	149	150	151	152	153	154	155	156	157	158	159	160
161	162	163	164	165	166	167	168	169	170	171	172	173	174	175	176	177	178	179	180
181	182	183	184	185	186	187	188	189	190	191	192	193	194	195	196	197	198	199	200
201	202	203	204	205	206	207	208	209	210	211	212	213	214	215	216	217	218	219	220
221	222	223	224	225	226	227	228	229	230	231	232	233	234	235	236	237	238	239	240
241	242	243	244	245	246	247	248	249	250	251	252	253	254	255	256	257	258	259	260
261	262	263	264	265	266	267	268	269	270	271	272	273	274	275	276	277	278	279	280
281	282	283	284	285	286	287	288	289	290	291	292	293	294	295	296	297	298	299	300
301	302	303	304	305	306	307	308	309	310	311	312	313	314	315	316	317	318	319	320
321	322	323	324	325	326	327	328	329	330	331	332	333	334	335	336	337*	338	339	340
341	342	343	344	345	346	347	348	349	350	351	352	353	354	355	356	357	358	359	360
361	362	363	364	365	366														

This table allows us to calculate the probability that a randomly chosen number within the range is part of the pattern.

It also enables us to take all the numbers from a certain event and see if they are part of the pattern.

The table will also be used as a basis for creating a calender showing all the dates of the year and high-lighting those connected to the pattern.

JAN	FEB	MAR	APR	MAY	JUN	JUL	AUG	SEP	OCT	NOV	DEC
1	1	1	1	1	1	1	1	1	101	111	121
2	33 ^d	2	2	2	2	27	28	2	-90 th	211	2
3	3	33	63 ^d	3	63	37	3	39	311	3	337 th *
4	4	63 ^d	44	4	4	47	48	4	4	4	4
5	5	5	5	125 th	56	5	5	59	5	5	5
6	37 th	63	6	6	6	6	6	6	6	6	6
7	27 [*]	37	47	7	7	77	7	7	7	7	7
8	28 [*]	8	48	8	8	189 th	8	8	8	118	8
9	9	39	99 th	9	9	9	9	99 [*]	9	119	9
101	10	10	100 th	10	10	10	10	10	10	10	10
111	211	311	101 st	11	11	11	223 th	9-11 [*]	11	11	11
121	12	12	12	12	12	12	12	12	12	12	12
113	44 th	13	13	13	13	13	13	13	13	13	13
14	14	14	14	14	14	14	14	14	14	-47 th	14
15	15	15	15	15	15	15	15	15	15	15	15
16	47 th	16	16	16	16	16	-137 th	16	16	16	16
17	17	17	17	137 th	17	17	17	17	17	17	17
118	18	77 th	18	18	18	18	18	189	18	18	18
119	19	19	19	19	19	19	231 th	19	19	19	19
20	20	20	20	20	20	20	20	20	20	20	20
211	21	21	111 th	21	21	21	21	21	21	21	21
22	22	223	22	-223 th	22	22	22	22	22	22	22
231	223	23	23	23	23	23	23	23	23	23	23
24	24	24	24	144 th	24	24	24	24	24	24	24
25	56 th	25	25	25	25	25	25	25	25	25	25
26	26	26	26	26	26	26	26	26	26	26	26
27 th *	27	27	27	27	27	27	27	27	27	27	27
28	28	28	118 th	28	28	28	28	28	28	-33 rd	28
29		29	119 th	29	29	29	29	29	29	29	29
33		30	30	30	30	30	30	30	30	30	30
311		90 th		31		31	31		31		31

I must be mentioned that the table and the calendar are not comprehensive representations of the pattern. The pattern consists of many more numbers. The table and the calendar only highlights those numbers that can be derived using the rules and conditions that are set for this study.

One example of a number that should be part of the pattern is 313, the registration number of Donald Ducks car. 313 contains 33, 13 and 93. It is also the remainder when 47 degrees are subtracted from 360 degrees.

The full pattern consists of numbers based on a wide variety of concepts. The main concept is however the one special version of the freemasonic logo. To make this study scientifically stringent we only use the main concept of the pattern.

In the final discussions we will however calculate a set of different probabilities using figures for more comprehensive patterns and numbers.

Even though the result of this study will be far from accurate it will still help the reader to get a basic comprehension of how the evidence is to be understood.

The result will not be accurate but after reading this chapter you will understand the scientific value of this evidence.

Thesis:

There is a numerological pattern built around one version of the freemasonic logo embedded in the date, the time and the amount of victims in nine eleven and the three largest attacks in Europe with respect to the number of casualties.

Method:

1. To prove or disprove the thesis we will classify and categorize all the numbers within a certain range and give them a value depending on how well they connect to the numerological pattern.

The range chosen is from 21-366.

The numbers 1-20 are excluded from the range as they are too low and will therefore occur too frequently by chance.

The range extends all the way up to 365 so that it can be applicably classifying and categorizing the dates of a normal year.

The numbers within the range will be categorized depending on how much creativity that is needed to connect them to the fundamental numbers of the pattern.

Numbers carrying multiple connections to the pattern will get higher value.

2. The next step is to take the numbers that have been classified as part of the pattern and transmute them into dates. This will generate a calendar showing how the days of the year correspond to the numerological pattern.

3. Once all numbers and all dates are categorized the next step is to compare how well the numbers and the dates from the attacks match the categorized pattern.

4. We will also have a discussion around the point of time of the events. The reason we don't make a table is that the amount of possible combinations of hour, minute and second is 86'400 (24x60x60).

5. Once we know how well our four cases match the pattern we can finally calculate the possibility of reaching the same level of match or consistency with the pattern by chance.

Step 1: Categorizing numbers.

The picture to the right shows all the numbers that can be derived from the version of the freemasonic logo that is claimed to be the foundation of the numerological pattern. We will call them primary numbers.

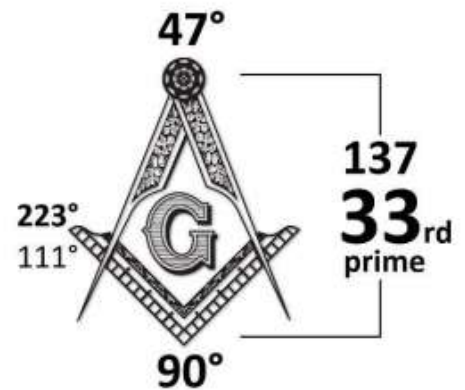

The primary numbers are 33, 47, 90, 111, 137 and 223.

If we apply creativity to the primary numbers we still stay connected to the logo but now one step further away. The numbers that can be extracted from the primary numbers are considered secondary numbers.

33.) 137 is the 33rd prime. 137 is therefore to be considered a secondary number. As it is already a primary number we will make it a multi-reference.

33 is factorized as 3x11. 113 and 311 are considered as secondary numbers.

33 can also be seen as 3^3 which is 27 and within the range.

The primary number 33 gives us the following secondary numbers: 27, 113, 137 and 311

47.) 211 is the 47th prime.

$4 \times 7 = 28$.

47 can also be mirrored to give us 74

47 gives us 28, 74 and 211.

90.) Does not give us any numbers within range.

111.) 111 can be factorized as 3×37 . This gives us the number 337.

137.) 137 is the 33rd prime and will therefore make 33 a multi-connector.

223.) Is the 48th prime.

223 can be mirrored to give 322.

The secondary numbers extracted from the primary numbers are: 27, 28, 48, 74, 113, 211, 311, 322 and 337

The main theme of the pattern is however to combine the 47 of the compass with the 90 of the square,

sometimes including a 7. As addition and multiplication are combinatoric while subtraction and division are not, we will only use the first two.

Addition without G

	3	11	28	47
90	93	101	118	137
9	12 / 39	20 / 9-11	37	56

Addition with G

	3	11	28	47
90+7	100	108	125	144
9+7	19	27	44	63

Multiplication without G

	3	11	28	47
90	270	990	2520	4230
9	27	99	252	423

Multiplication with G

	3	11	28	47
90x7	1890	6930	17640	29610
9x7	189	693	1764	2961

Another way to mathematically understand the square is by seeing it as a square instead of as 90 degrees. This allows us to square the different expressions of 47.

47 Squared

	3	11	28	47
^2	9	121	784	2209

Yet another way of combining the numbers in the logo is by taking 33 for the compass and the square and combining it with 7 for G. This gives us the numbers 231 and 337.

The number 77 is a visual reference to the compass and the square. The number 777 would have been included as a reference to the whole logo was it within range.

The secondary numbers extracted through combinations of the compass, the G and the square are: 27, 37, 39, 44, 56, 63, 77, 93, 99, 101, 121, 118, 119, 189, 231, 252 and 337.

The secondary numbers extracted directly from the primary numbers are: 27, 28, 48, 74, 113, 211, 311, 322 and 337

Comparing the numbers we see that 27 and 337 are multi-connectors.

As a final step we will also include all the prime relations that the secondary numbers are part of. A prime relation is for example that 103 is the 27th prime. 103 is therefore a tertiary number. It is two steps of creativity away from the logo.

A prime relation is specific connection between two numbers. All numbers are not primes but all numbers have a prime relation. We could also expand the pattern by including factorizations, mirroring and internal multiplications but for this study we stick to the primes as it is a more specific form of relation.

The prime relations are:

$$28^{\text{th}} = 107, \quad 37^{\text{th}} = 157, \quad 44^{\text{th}} = 193, \quad 56^{\text{th}} = 263,$$

$$63^{\text{rd}} = 307$$

$$337 = 68^{\text{th}}, \quad 311 = 64^{\text{th}}, \quad 113 = 30^{\text{th}},$$

The prime relations to secondary numbers give us the following tertiary numbers: 30, 64, 68, 107, 157, 193, 263, 307.

The table below shows all the numbers of the pattern within the range 21-365.

21	22	23	24	25	26	27*	28	29	30	31	32	33*	34	35	36	37	38	39	40
41	42	43	44	45	46	47	48	49	50	51	52	53	54	55	56	57	58	59	60
61	62	63	64	65	66	67	68	69	70	71	72	73	74	75	76	77	78	79	80
81	82	83	84	85	86	87	88	89	90	91	92	93	94	95	96	97	98	99	100
101	102	103	104	105	106	107	108	109	110	111*	112	113	114	115	116	117	118	119	120
121	122	123	124	125	126	127	128	129	130	131	132	133	134	135	136	137**	138	139	140
141	142	143	144	145	146	147	148	149	150	151	152	153	154	155	156	157	158	159	160
161	162	163	164	165	166	167	168	169	170	171	172	173	174	175	176	177	178	179	180
181	182	183	184	185	186	187	188	189	190	191	192	193	194	195	196	197	198	199	200
201	202	203	204	205	206	207	208	209	210	211	212	213	214	215	216	217	218	219	220
221	222	223	224	225	226	227	228	229	230	231	232	233	234	235	236	237	238	239	240
241	242	243	244	245	246	247	248	249	250	251	252	253	254	255	256	257	258	259	260
261	262	263	264	265	266	267	268	269	270	271	272	273	274	275	276	277	278	279	280
281	282	283	284	285	286	287	288	289	290	291	292	293	294	295	296	297	298	299	300
301	302	303	304	305	306	307	308	309	310	311	312	313	314	315	316	317	318	319	320
321	322	323	324	325	326	327	328	329	330	331	332	333	334	335	336	337*	338	339	340
341	342	343	344	345	346	347	348	349	350	351	352	353	354	355	356	357	358	359	360
361	362	363	364	365	366														

Primary

Secondary

Tertiary

* = Multi-connector

In a range of totally 346 numbers there are 38 numbers that correspond to the logo. Four out of these are multi-connectors.

The probability of any randomly chosen number to be part of the pattern is 38 out of 346 or about 11%.

Looking at the table we see that the numbers that constitute the pattern are concentrated among the lower numbers. If we would set the range to be 21-120 then we would have a range consisting of only 100 numbers and 24 of them would be part of the pattern. The probability of randomly picking a number that is part of the pattern is then 24%. This will be further discussed later on.

Out of the 38 numbers that constitute the pattern 6 are primary numbers, 24 are secondary numbers and 8 are tertiary numbers.

Step 2: Categorizing dates.

The dates are classified based on how they relate to the numbers classified in the previous section.

Each date can be seen as holding several numbers.

1. One number depending on which day of the year it is.
2. One number depending on how many days that remain until the end of the year.
3. One number for the month and day combination.
4. One number for the day and month combination.

The dates will be classified as follows.

1. If the date is the same day of the year as a number in the pattern then that date will be regarded to as strong as that number.
2. If the number of days that remain until the end of the year is the same as a primary number then that date will be regarded as secondary date. The dates will not include tertiary numbers as the fact that each date can be seen in several different ways already creates a sufficient richness of dates using only primary and secondary numbers.
- 3 & 4. If the number of the month and day, put one after another, forms the a number in the pattern then that date is considered equivalent of that number.

Let's take the example of the number 137 as an example of how numbers are turned into dates.

1. The 137th day of the year is May 17th. This date is therefore a primary date. If we have a leap year, meaning that February got 29 days, then the 16th of May will become the 137th day of the year.

2. There are two different ways to count how many days that remain until the end of the year. One is to include the present day, the other is not to include it.

If you Google a date then Google will give you the number of the day of the year and it will tell you how many days that remain until the end of the year. Google is in its calculations not including the present day and that is the closest we will get to a scientific judgement on that matter.

On the 16th of August there remains 137 days until the end of the year. The number 137 is a primary so the 16th of August will be seen as a secondary date.

3 & 4. 137 contains 1-37 and 13-7. As there are neither 37 days in a month nor 13 months in a year the only possible connection is that to 13th of July. That date is therefore considered as a primary date.

If we apply this described procedure to all the dates of the normal year we get the following calendar:

JAN	FEB	MAR	APR	MAY	JUN	JUL	AUG	SEP	OCT	NOV	DEC
1	1	1	1	1	1	1	1	1	101	111	121
2	33 ^d	2	2	2	2	27	28	2	-90 th	211	2
3	3	33	63 ^d	3	63	37	3	39	311	3	337 ^{th*}
4	4	63 ^d	44	4	4	47	48	4	4	4	4
5	5	5	5	125 th	56	5	5	59	5	5	5
6	37 th	63	6	6	6	6	6	6	6	6	6
7	27 [*]	37	47	7	7	77	7	7	7	7	7
8	28 [*]	8	48	8	8	189 th	8	8	8	118	8
9	9	39	99 th	9	9	9	9	99 [*]	9	119	9
101	10	10	100 th	10	10	10	10	10	10	10	10
111	211	311	101 st	11	11	11	223 th	9-11 [*]	11	11	11
121	12	12	12	12	12	12	12	12	12	12	12
113	44 th	13	13	13	13	13	13	13	13	13	13
14	14	14	14	14	14	14	14	14	14	-47 th	14
15	15	15	15	15	15	15	15	15	15	15	15
16	47 th	16	16	16	16	16	-137 th	16	16	16	16
17	17	17	17	137 th	17	17	17	17	17	17	17
118	18	77 th	18	18	18	18	18	189	18	18	18
119	19	19	19	19	19	19	231 th	19	19	19	19
20	20	20	20	20	20	20	20	20	20	20	20
211	21	21	111 th	21	21	21	21	21	21	21	21
22	22	223	22	-223 th	22	22	22	22	22	22	22
231	223	23	23	23	23	23	23	23	23	23	23
24	24	24	24	144 th	24	24	24	24	24	24	24
25	56 th	25	25	25	25	25	25	25	25	25	25
26	26	26	26	26	26	26	26	26	26	26	26
27 ^{th*}	27	27	27	27	27	27	27	27	27	27	27
28	28	28	118 th	28	28	28	28	28	28	-33 rd	28
29		29	119 th	29	29	29	29	29	29	29	29
33		30	30	30	30	30	30	30	30	30	30
311		90 th		31	31	31	31	31	31	31	31

The calendar shows the 365 days of a normal year and how they relate to the numbers of this one special version of the freemasonic logo.

Out of the 365 days a total of 70 are marked as being part of the numerological pattern. This means that the probability that a randomly chosen date is part of the pattern is $70 / 365$ or 19,2%.

Step 3: Categorizing times.

To categorize all the 86'400 seconds of the day is a task too overwhelming for its beneficiary contribution, especially since the vast majority of these numbers are out of range and a new much larger table of numbers would need to be produced.

Instead the times of the events will be “scrutinized” and we will make an attempt at applying reasonable judgement when determining whether a certain point of time is part of the pattern or not.

As it comes for the probability of any randomly chosen point of time being part of the pattern we will use the same probability as for the dates. More about this in the final discussions.

Step 4: Comparing cases with pattern.

The four cases:

1. Nine eleven happened on the 11th of September 2001. The attack consisted of several separate incidents.

In the twin tower part happened at 8:46:30 and had totally 157 casualties., In the Pentagon attack, that happened at 9:37 there were 189 dead and the flight 93 crash at 10:03 had 44 victims

This gives us the date 11th of September, the times 8:46, 9:37 and 10:03 as well as the numbers 44, 157 and 189.

2. The Madrid attack happened on the 11th of March 2004: a leap year. There were a total of 193 casualties. The attack started at 7:37.

3. The Paris Bombing happened on the 13th and 14th of November 2015. It started at 21:16 There were a total of 137 casualties.

4. The London 2005 bombings happened at 8:49 and 9:47 on the 7th of July 2005 and carried a total of 56 casualties.

We have the dates: 9/11, 3/11, 11/13, 11/14 and 7/7.

We have the times: 7:37, 8:46, 8:49, 9:37, 9:47 and 21:16

We have the numbers 44, 56, 137, 157, 189, and 193.

If we compare the dates to the calendar we see that:

- 9/11 is a multi-connector.
- 3/11 is a secondary date.
- 11/13 is not part of the pattern.
- 11/14 is a secondary date.
- 7/7 is a secondary date.

4 out of 5 dates are part of the pattern:

If we compare the numbers to the pattern we get that:

- 44 is a secondary number
- 56 is a secondary number
- 137 is a primary multi-connector
- 157 is a tertiary number
- 189 is a secondary number
- 193 is a tertiary number

Six out of six numbers are part of the pattern.

Step 5: The points of times

7:37.) This point of time can be seen as a reference to the whole masonic logo. 7 for the G and 37 as a combination between 47 and 90 as $4 \times 7 + 9 + 0$ is 37.

The combination of 7 and 37 therefore makes sense.

8:46.) As this is the 47th minute of the 9th hour it is clearly within the pattern.

8:49.) This is 11 minutes to 9. As 9-11 is such a fundamental number this must be seen as part of the pattern.

9:37.) This is from the Pentagon attack where $9 \times 3 \times 7$ persons died. This point of time can be seen as 9-0, 4-7 and G. It is regarded as part of the pattern.

9:47.) Could be the most primary point of time of the whole day.

10:03.) The point of time 10:03:11 contains the multi-connector 311. 10:03 is chosen as it is from the last “attack” of 9/11 and thereby closes the whole attack at

duration of 77 minutes. It can be considered to be part of the pattern.

21:16.) The major points of time chosen for the Paris attack all correspond to a concept within Freemasonry called the 47th problem of Euclid. The numbers of this concept are not part of the pattern used in this study, the number 47 is however a primary number.

The 47 problem of Euclid is a officially acknowledged concept within freemasonry, as are the numbers in it that correspond to the points of time in the Paris attack. It is reasonable to consider it as part of the pattern, we will however not do so. The reason is that we are trying a thesis and if we prove that thesis based on the assumption that 21:16 is part of the pattern then that conclusion can be questioned. If we however prove that thesis despite falsely considering 21:16 as not being part of the pattern, then that conclusion is harder to question.

This gives us a total of 6 out of 7 times matching the pattern.

Step 5: Calculating the probability.

Dates:

We have four out of five dates in accordance with the pattern.

The probability of any random date being part of the pattern is 19,2%.

The probability of randomly choosing five out of five dates that match the pattern is:

$$0,192 \times 0,192 \times 0,192 \times 0,192 \times 0,192 = 0,00026 \text{ or } 0,026\%$$

This is because 19,2% is 0,192 in decimal form. Five out of five dates means that we have to hit the probability of 0,192 five times in a row. This is mathematically expressed as $0,192 \times 0,192 \times 0,192 \times 0,192 \times 0,192$

The probability of a date not being part of the pattern is $100\% - 19,2\%$ which equals 80,8% or 0,808 in decimal form.

There are five different combinations that give 4 out of 5 in accordance with the pattern. 4 out of 5 means that one is wrong. As there are five different dates there are five dates that can be wrong, hence five different combinations:

Date 1	Date 2	Date 3	Date 4	Date 5
0	1	1	1	1
1	0	1	1	1
1	1	0	1	1
1	1	1	0	1
1	1	1	1	0

All these five combinations have the same probability of occurring. The probability is calculated by taking the probability of one date not being part of the pattern and multiplying it four times with the probability of a date being part of the pattern:

$$0,808 \times 0,192 \times 0,192 \times 0,192 \times 0,192 = 0,0011 \text{ or } 0,11\%.$$

As there are five different combinations that generate 4 out of 5 we have to multiply that result with 5.

$$0,11\% \times 5 = 0,55\%$$

Now we have calculated to probabilities of getting 5 out of 5 as well as 4 out of 5. If we add these two together we get the probability of getting 4 or more out of 5.

$$0,55\% + 0,03\% = 0,58\% \text{ or about } 1 \text{ in } 172.$$

Numbers:

As we have 6 out of 6 six numbers that are part of the pattern the calculation of probability is very straight forward. We just take the probability of any number being part of the pattern and then multiply it six times.

The probability was about 11% or 0,11 in decimal form.

$0,11 \times 0,11 \times 0,11 \times 0,11 \times 0,11 \times 0,11 = 0,0000018$ or 0,00018%.

To understand the figure better we can see it as 1 in 570'533.

The probability that 6 out of 6 numbers match the pattern by chance is 1 in 570'533

To get the probability that 4 out of 5 dates match the pattern in the same cases that 6 out of 6 numbers do, we need to multiply the probabilities with each other.

From the dates we got the probability of 1 in 172. From the numbers 1 in 570'533.

$(1/172) \times (1/570'533) = 1/98'131'783$

1 in 98'131'783.

This is somewhat the equivalent of not at all knowing someone's phone number but still picking the phone up, giving it a wild guess and getting it right.

Times:

We had 6 out of 7 times in accordance with the pattern.

As we have not calculated the probability of a certain time being part of the pattern we have to make an assumption or a guess. Not to be too low and thereby invalidate the findings of the study the probability of a time being part of the pattern is to be regarded as that twice of a date.

$$19,2 \% \times 2 = 38.4\%$$

The probability of getting 7 out of 7 is 0,123%

The probability of getting 6 out of 7 is 2,963%

Add them together to get the probability of getting 6 or more out of 7.

$$0,123\% + 2,963\% = 3,086\% \text{ or } 1 \text{ in } 32,4$$

To combine the probability of having 6 out of 7 points of time, 6 out of 6 numbers and 4 out of 5 dates we have to multiply the individual probabilities with each other.

We had 1 in 98'131'783 from before. Now we have 1 in 32. Multiplying them together we get one 1 in 3'140'217'056.

This is the equivalent of flipping a coin 31 times and getting tails every time.

It is the equivalent of throwing 13 dices at once and getting the same number on all of them.

These astronomical figures might feel unrealistic. If we however account for the possibility that a lot of effort has been put into choosing the numbers for nine eleven and the other terror attacks and that the purpose has been to generate unwavering consistency with the pattern then they are fully possible.

The only way to achieve these levels of probability is if the numbers are in fact chosen and not random. If they are chosen then this is the level of probability that we can expect.

This is the proof. It's that simple.

Alternative calculations

Let's say that 77 is not a visual reference to the logo and therefore not part of the pattern. The date 7/7 is then not part of the pattern meaning that we only have 3 out of 5 dates in accordance with the pattern. Let's further also say, somewhat contractionary, that the probability of any random date being part of the pattern is not only 19,2% but actually 25%.

Let's say that the tertiary numbers are not part of the pattern meaning that we do not have 6 out of 6 numbers but only 4 out of 6 and that the probability of any number being part of the pattern is not only 11% but in fact 20%.

Let's also say that 8:49 being 11 minutes to 9 and therefore a reference to 4+7 and 9+0 is way too far reaching resulting in only 5 of 7 times being part of the pattern but the probability of any random date being part of the pattern is still 38,4%

The probability of getting 3 or more dates out of 5 would then be 10,35%

The probability of getting 4 or more numbers out of 6 would then be 1,7%

The probability of getting 5 or more times out of 7 would be 8,16%.

The combined probability of randomly selected dates, numbers and times to match the patterns with the same consistency as in these four cases would then be:

$$0,1035 \times 0,017 \times 0,081 = 0,00014 \text{ or } 0,014\%$$

This is 1 in 7017.

It is the same probability as flipping heads 12 times in a row or as throwing seven dices and getting the same number on all of them. It does not happen. You don't throw seven dices and in one try get the same number on all of them, not when the dice carries the logo of freemasonry.

Even by cheating we still cannot deny the obvious fact. This is the evidence.

The realistic point of view.

The dates: We know that all the dates are part of the pattern.

November 13th was chosen because it was Friday the 13th and that the attack was made to last until the next day as that day was a reference to 47.

3:11 as in the date of the Madrid attack, is not only the factorization of 33 but also the 64th prime number and 137 in hexadecimal.

The number 77 is a primary number of the pattern. It is probably one of the most used numbers. London 7/7 was of course a reference to this.

And we also have 9/11. Probably the date of the year that fits the pattern best as 9/11 is a reference to the compass and the logo while the fact that 111 days remains is a reference to G, or it's absence.

We have 5 of 5 dates as part of the pattern.

The numbers:

The twin tower attack should of course not be classified as a tertiary number, not when the 157 is made up of 137 and 9-11, divided among two planes in such a way that the planes also carry 9-11.

That such a constellation would occur by chance is not 11%. It's more towards one 1 in 1000 than 1 in 10.

The 44 from flight 93 contains $37+7$ as well as 33 and 47.

This constellation is also far less probable to occur by chance than 11%.

189 is a multi-connector made up out of 125 and 64.

The figure 1 in 3'140'217'056 might at first seem unrealistic but the true figure is most probably far more spectacular. The explanation cannot be anything else than that great effort has been put into choosing the numbers that best communicate freemasonry in a discrete way.

The big question is then why? Why leave the evidence out in the open?

As mentioned, one reason is that it forces those who have sworn to protect the secrets of masonry to also protect the secret that these attacks were not in fact orchestrated by Islamic fanatics but “inside jobs”. If people realize that nine eleven was an inside job they will also realize that there is a conspiracy.

Another reason that we will come to later is mind control. The use of symbols and numbers in plain sight is a form of mockery of those unable to see what is right in front of them.

Those at the top of the conspiratorical pyramid basically rule the world. They see themselves as superior beings. However they do not rule the world out in the open, they do so from the shadows. One could say that they are hiding and to hide is of course a sign of weakness. The symbols and the numbers allow them to feel like they are not hiding.

The reason we don't know is not because they hide, it is because we in our low state of consciousness are unable to recognize the patterns that are right in front of us and the meaning they carry.



They are there, written in stone, out in plain sight for billions to see. They are there with a possibility of 1 in trillion billions to be random.

The truth is that they are not hiding. The reason we don't see is because we are under mind control.

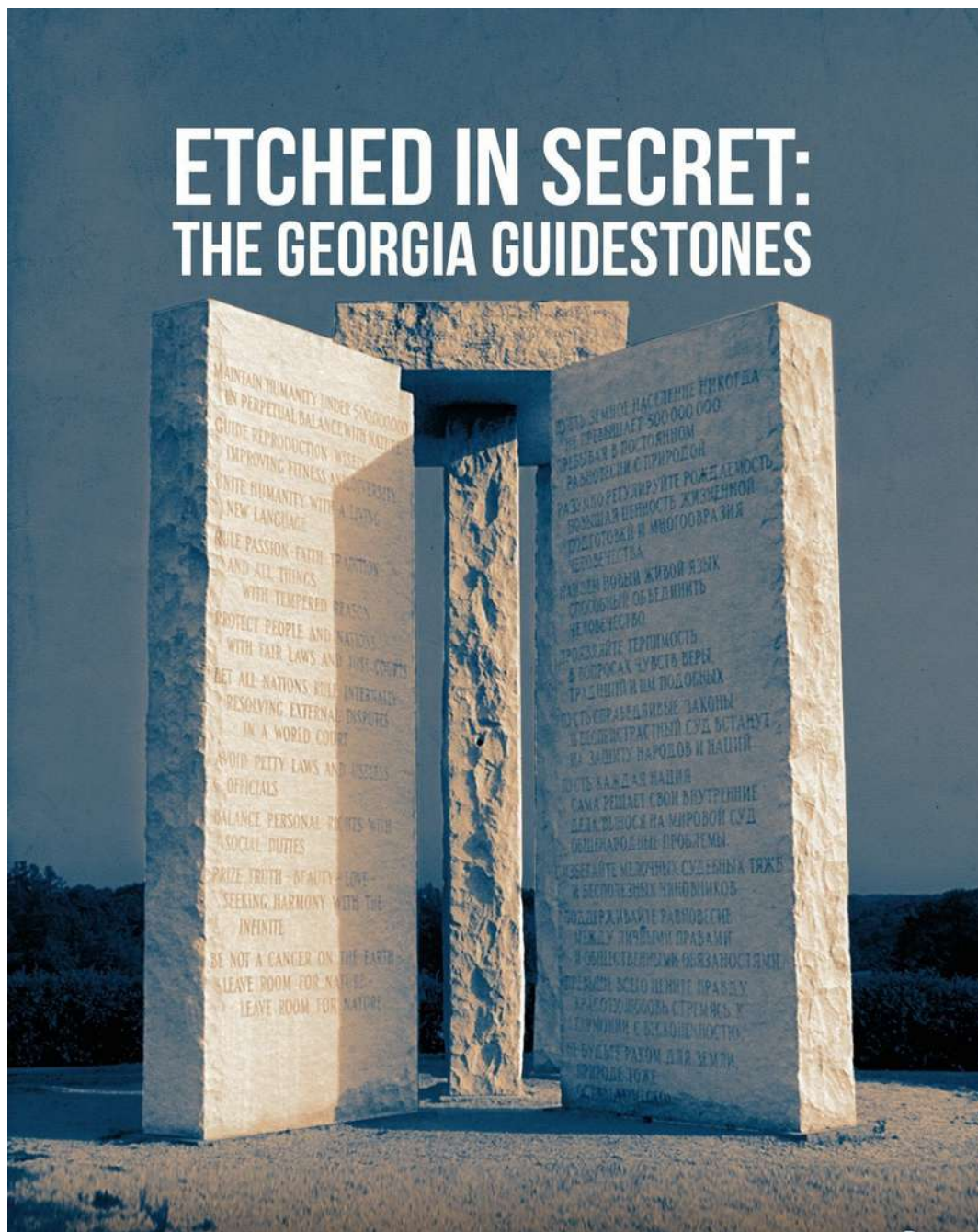

Chapter 4: Occult knowledge of the mind:

The word occult or occulted means hidden from sight. The occulted knowledge or the knowledge that is hidden is the knowledge about consciousness and the mind.

The knowledge about the mind is hidden and guarded in different secret societies. It is held from us and used to control us through mind control.



The use of symbolism is a way to occult knowledge and render it unintelligible for those not initiated into the meaning of the symbols.

Consciousness:



Consciousness is in this presentation defined as the ability to recognize patterns and meaning with respect to events taking place both within oneself as well as in the realm in which the self exists and operates. It is essentially our ability to recognize truth from falsehood.

Mind control is in its essence a war on consciousness. It's a war on our ability to recognize patterns; or to know what is actually going on, inside ourselves as well as in the realm in which we exist and operate.

When we don't know what goes on inside of ourselves and how the self functions then we are open to external control by those who do know.



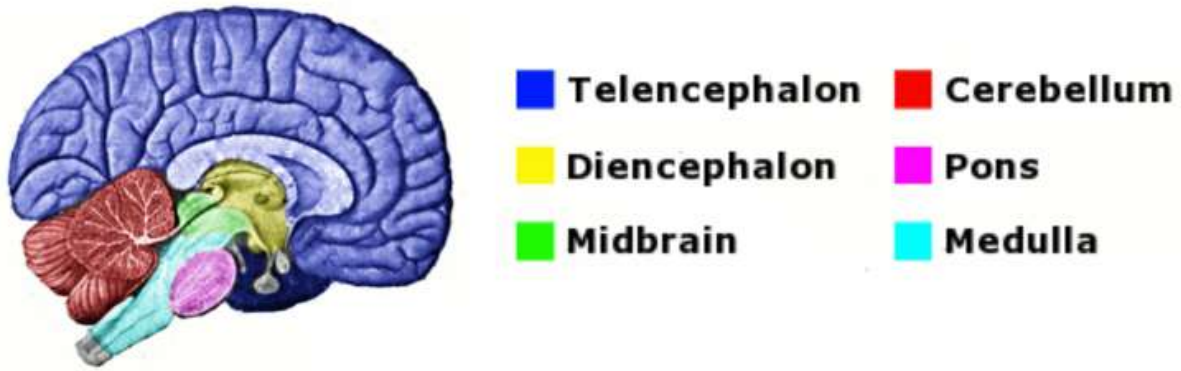

This chapter gives an introduction to the basic structure and mechanisms of human consciousness. It will give you tools to understand how your mind and consciousness functions and thereby helps you to be in greater control over your mind and consciousness.

Knowledge about the self is crucial in improving the quality of your experience here on earth. With the knowledge about the self and the mind you know how to raise consciousness and make yourself and those around you happier, healthier and experience a wider spectrum of life.

Knowledge about consciousness and the self is fundamental to understanding how the mind control that is being employed on us works. The better we understand it the better are we able to defend ourselves against it not to be affected by it. This chapter is hence an introduction to the knowledge about the mind while the next chapter is an introduction to basic techniques and methodologies of mind control.

Yin and Yang

Consciousness comes in two different forms. We can say that there are two basic ways in which consciousness breaks down and manifests. There is an internal feminine manifestation and an external masculine manifestation.

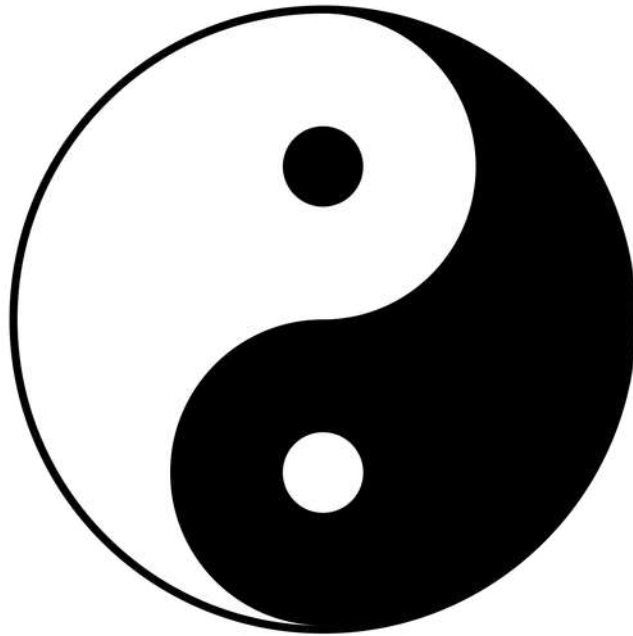

These two manifestations are not polarities but unified to form the whole of consciousness.

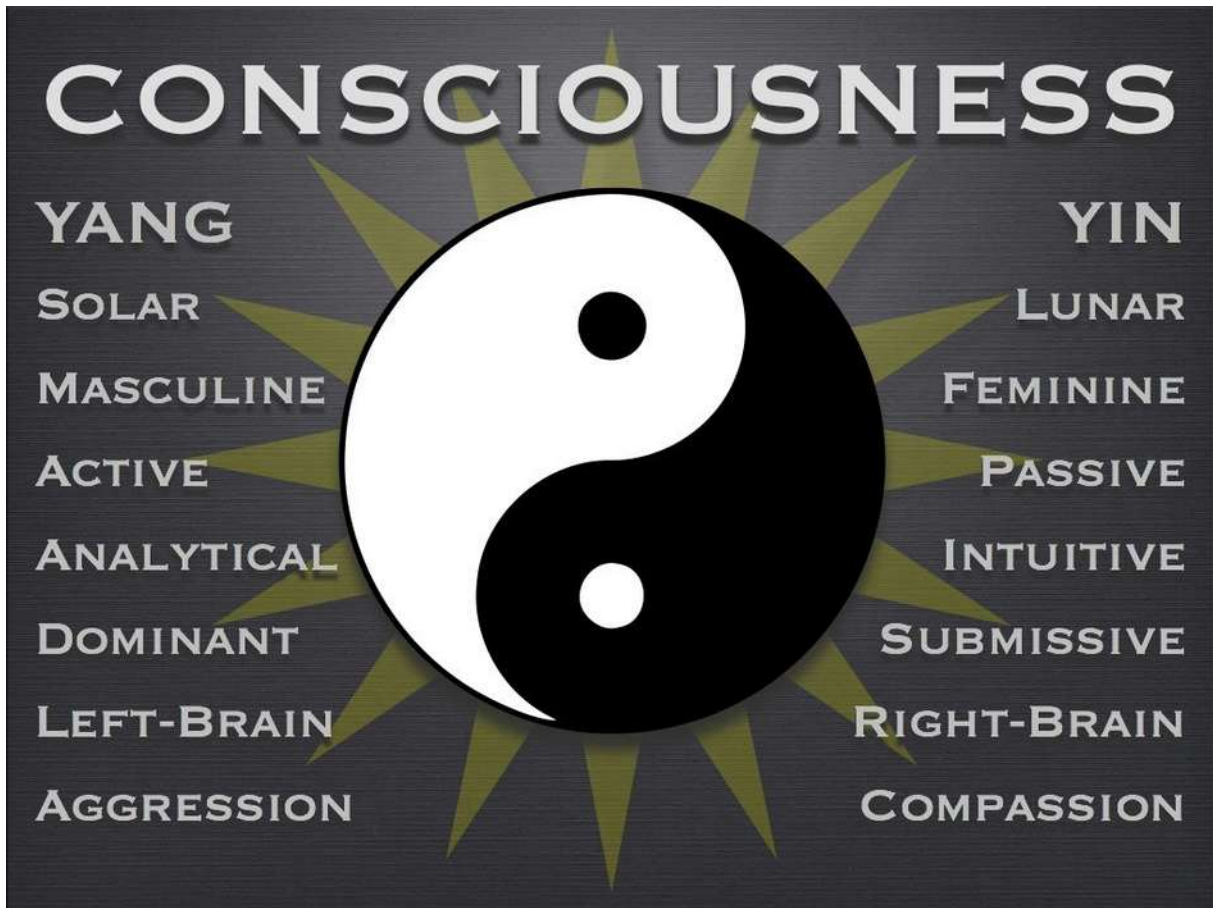

Yang, the masculine aspect of consciousness is dominant, active, analytical and logical. It's all about action and how our consciousness manifests to others in our shared reality.

Yin, the feminine aspect of consciousness is passive, intuitive, compassionate and submissive. It is directly related to our emotions as emotions are the internal quality of consciousness inside of us.

The masculine and the feminine *forms* of consciousness have different names in different schools and traditions. In Daoism they are called Yin and Yang. Yin being the feminine aspect while Yang is the masculine.



In freemasonry we have the two pillars Boaz and Jachin.

Boaz is feminine while Jachin is masculine



In the Kabbalah there is the Path of Severity (m) and the Path of Mercy (f)

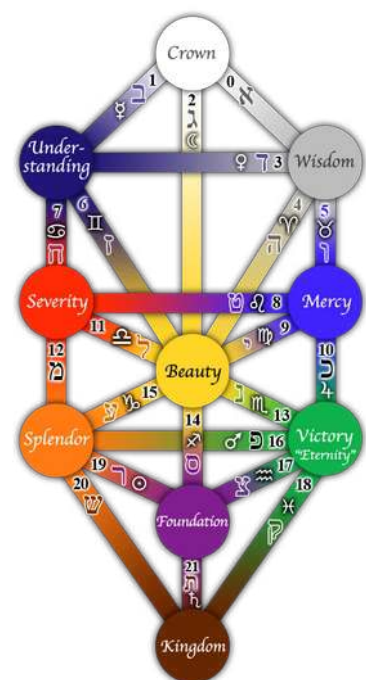

The Yin and Yang brain

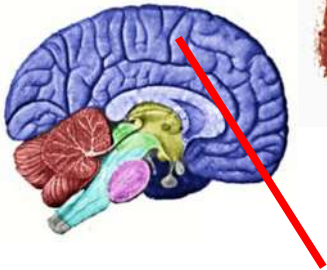
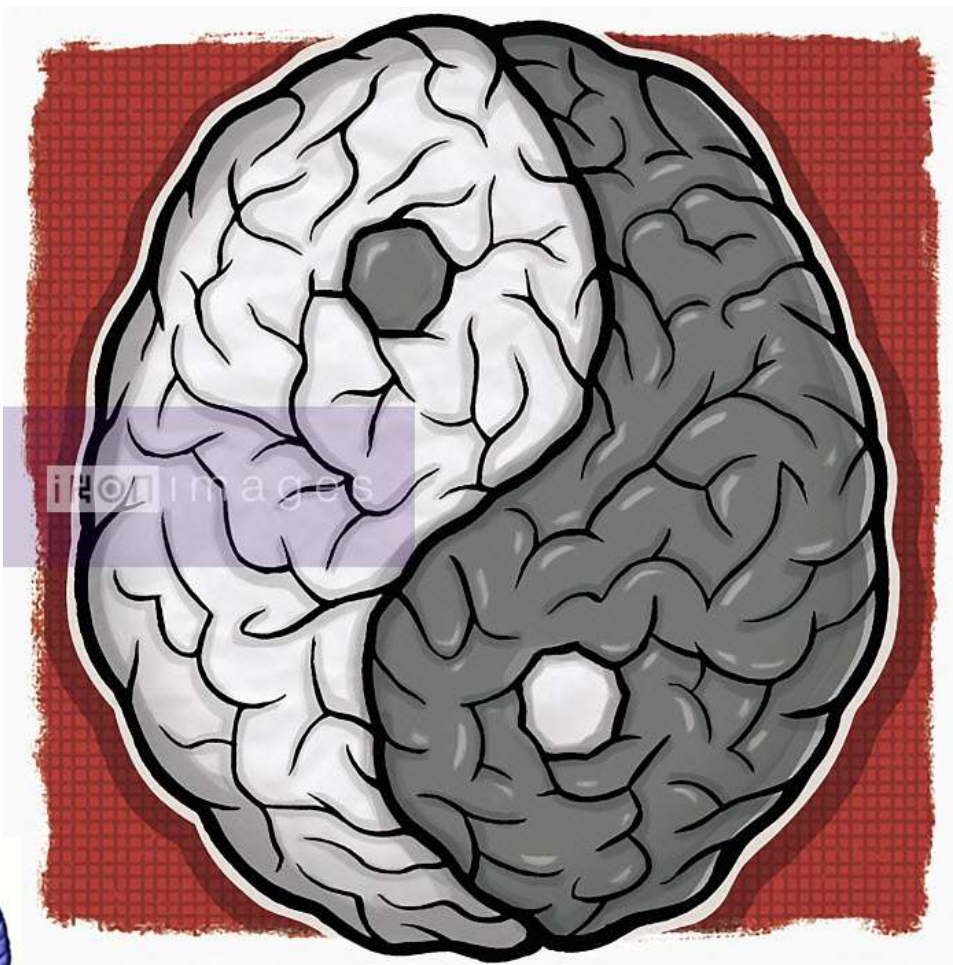

The neocortex of the human brain is bilaterally symmetrical. This means that the human brains has two brain halves that are symmetrical to each other.

The left brain half is masculine and associated with Yang while the left brain half is feminine and associated with Yin

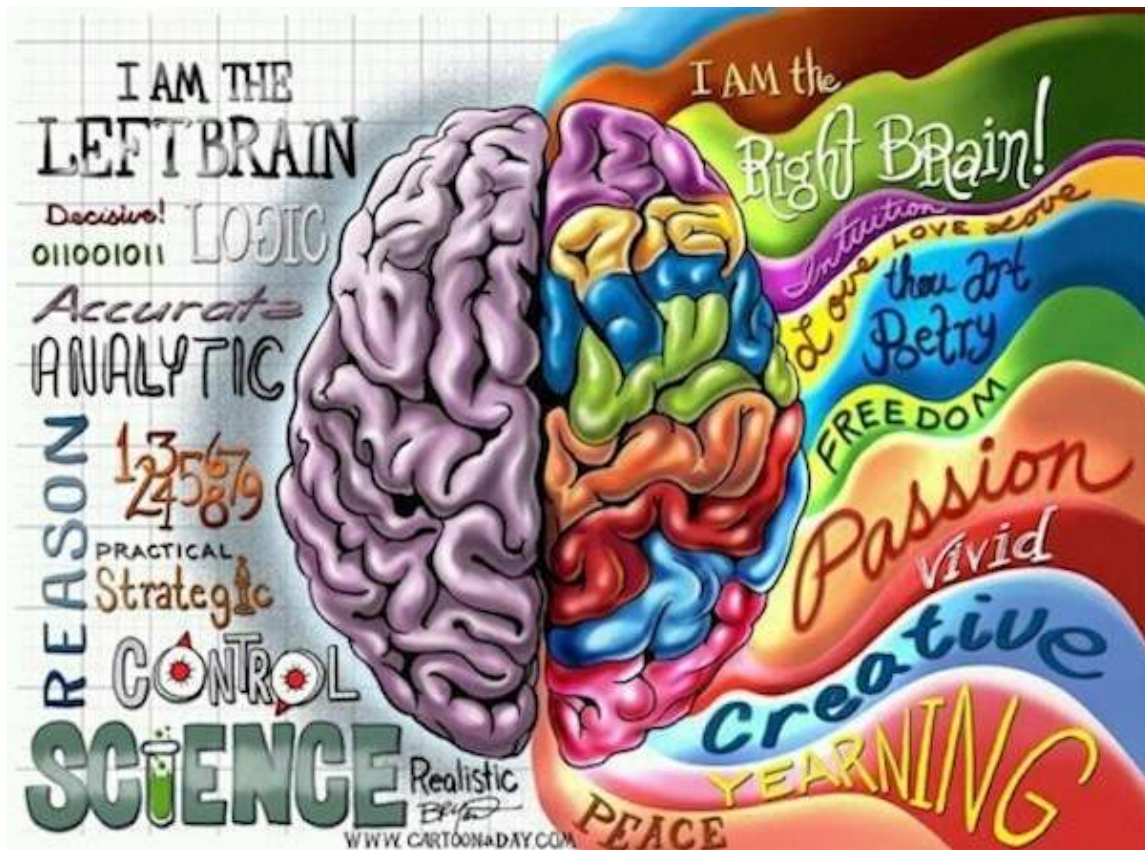

The masculine left brain half handles maths, analytical thought, logic, science and language. It's involved with the physical world around us.

The masculine form of consciousness is active and dominant. It is symbolized by the outward pointing triangle, the sun, masculine gods and the square.

The right brain is the Yin brain. It handles intuition, creativity, art, music, dance, holistic thought and a sense of oneness or connectedness.

It is associated with the right brain and symbolized by the inward pointing triangle, the moon, the goddess and the circle.

LEFT vs RIGHT BRAIN

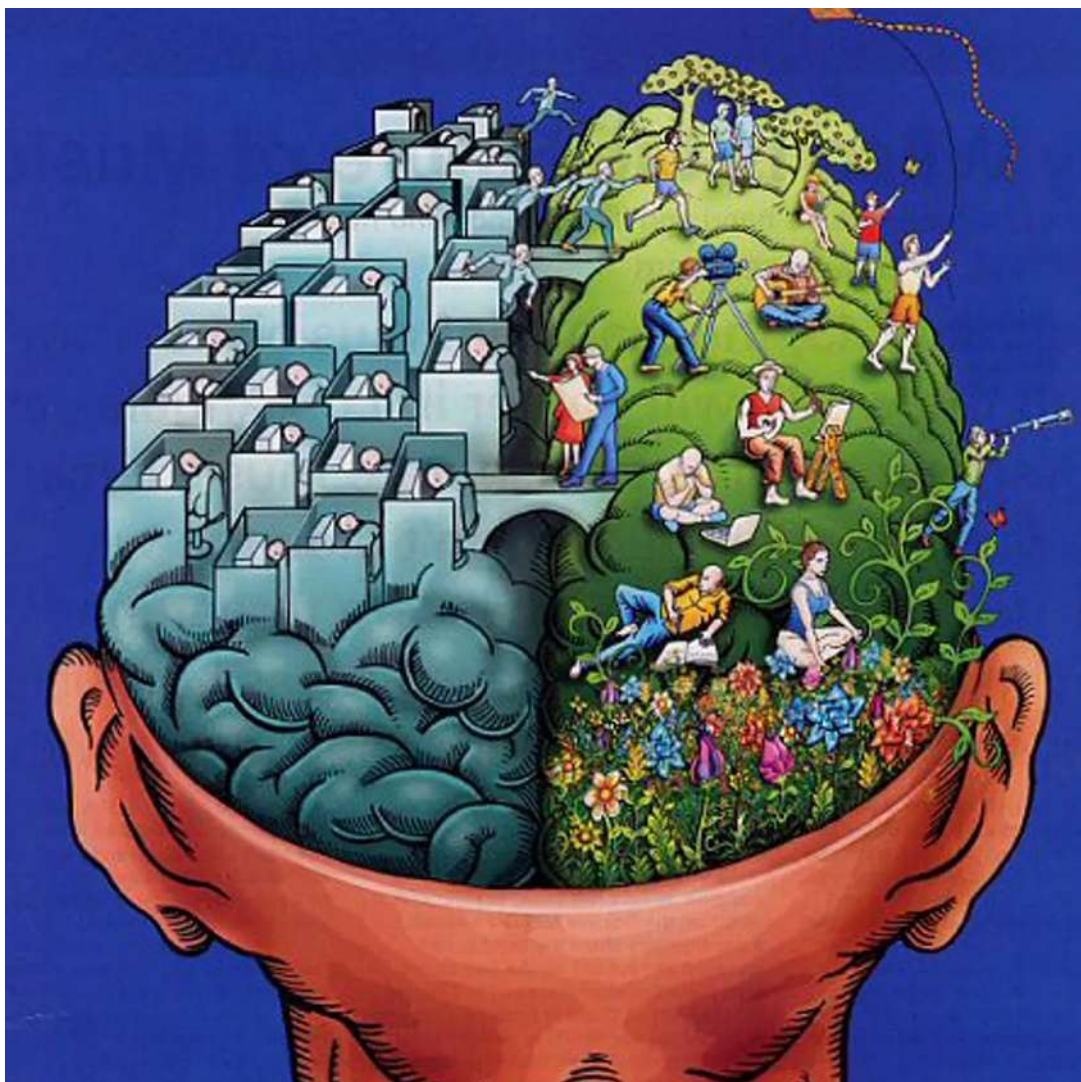
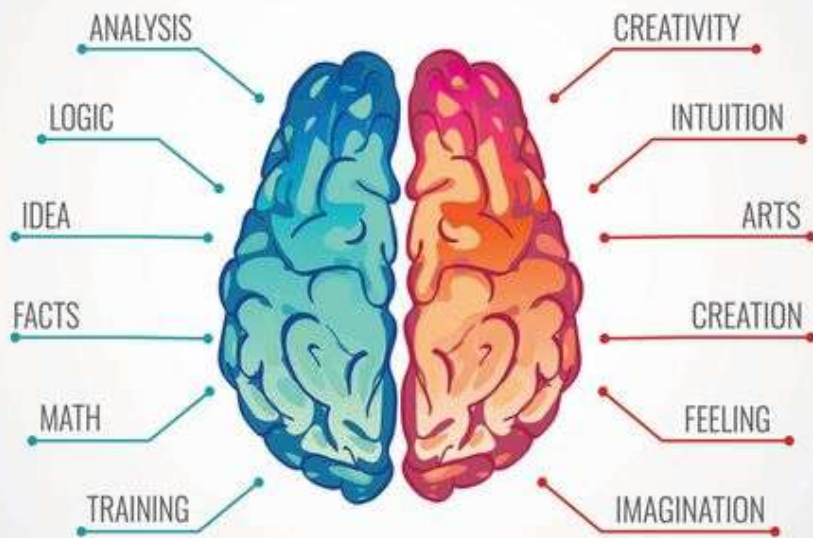

The way to become more conscious is through bringing the masculine and the feminine aspects of consciousness into unison with each other.

As Yang is about action and Yin about emotion it means that we should bring our actions and emotions into unison. Our actions should reflect how we truly feel.

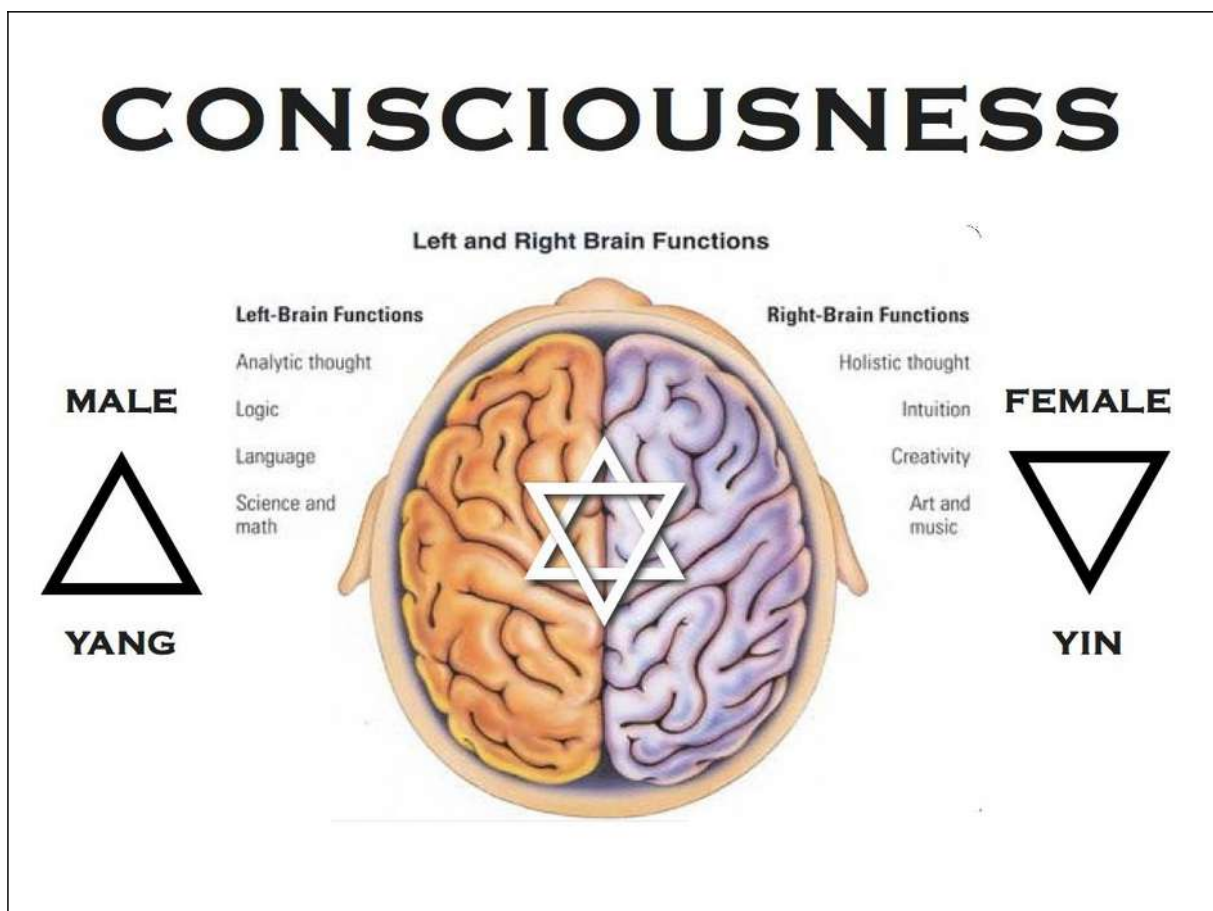

When the masculine and the feminine are in unison then the right and the left brain are communicating and cooperating fully. We use the whole brain on so our mental capacity increases and our spectrum of experience becomes richer. We experience more of life.

If something is morally wrong and we do it anyway, whatever the reason might be, then we are in opposition with ourselves. Acting against how we truly feel puts us in a state of internal opposition.

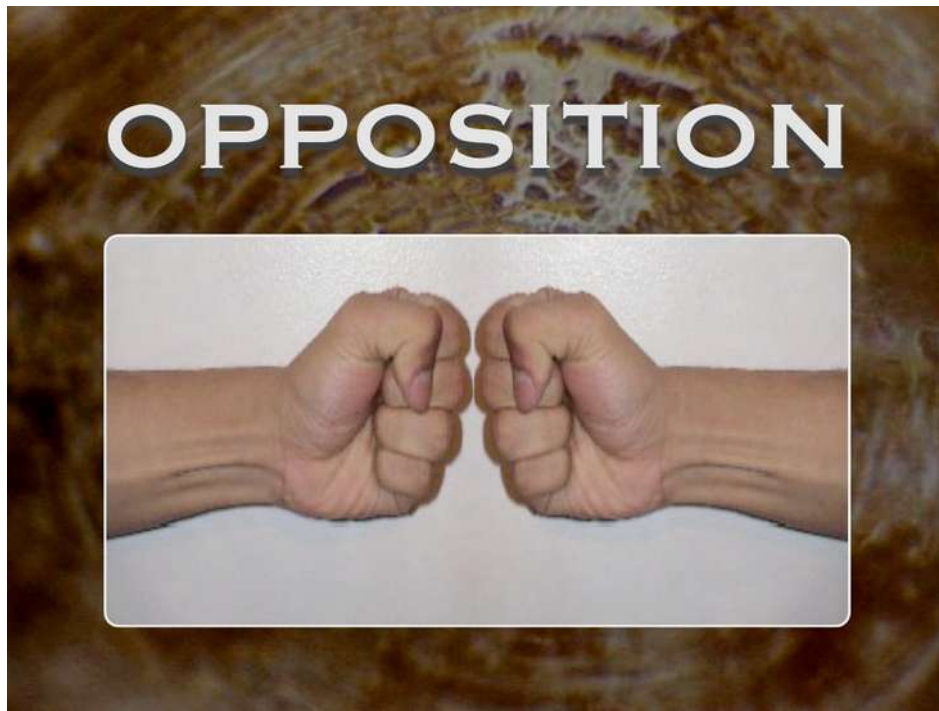

The state of internal opposition is when there is a disharmony between the masculine and the feminine. This manifests in one brain half dominating the other. Communication and cooperation is inhibited so we don't access all of our mental potential. We recognize less patterns inside and around us and we experience a smaller spectrum of experiences and emotions.



The foundation of all mind control is to put and keep us in a state of internal opposition. One reason is that it opens us up to different types of manipulation from outside. The masculine left brain sees the detail while the feminine right brain sees the big picture.

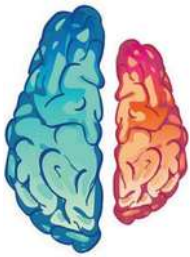

The left brain alone can see if the detail is correct but not if it fits into the bigger picture. When the left brain half is dominant the person becomes open for manipulation through logic which is in itself valid but which is in conflict and opposition to other values and beliefs held or propagated.



The right brain alone is uncritical of detail or unable to make judgements and draw logical conclusions regarding if something is reasonable or not. The right brain is open to believe everything that feels right, seems to be generally believed in society or comes from a seeming authority.



In other words: the left brain can spot the right or the wrong answer to a question but it needs the right brain to spot the wrong question being asked.

The state of internal opposition is also a state of internal confusion. As the feminine and the masculine, or the two brain halves, do not communicate properly but one is suppressing the other, it means that we don't get the whole balanced picture.

We don't have full information about how we feel inside and we don't use the full brain to process the information that we have. The result is that we don't truly know what is going on inside of us. We don't see clearly so we are confused.

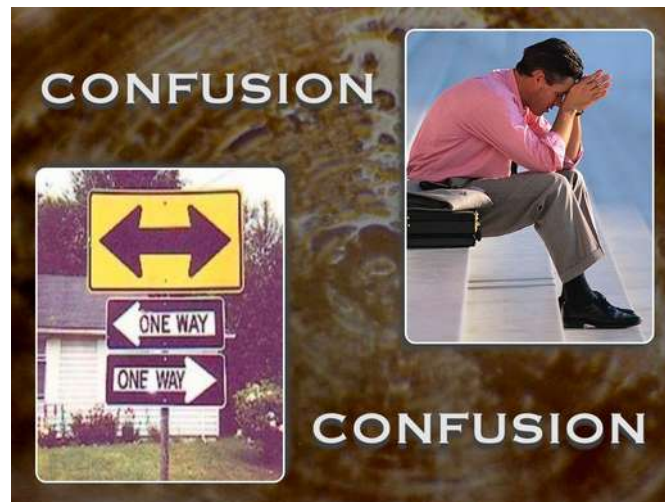

We don't know what's going on inside; we don't see clearly and we don't know what's true and false. This distortion of perception is not only internal but also external.

In the state of internal opposition and confusion we are unable to recognize truth from falsehood with respect to events taking place both within oneself as well as in the realm in which the self exists and operates. We see less patterns so we understand less of what's going on.

The seal of Solomon

The seal of Solomon is made up of two overlapping triangles within a circle.

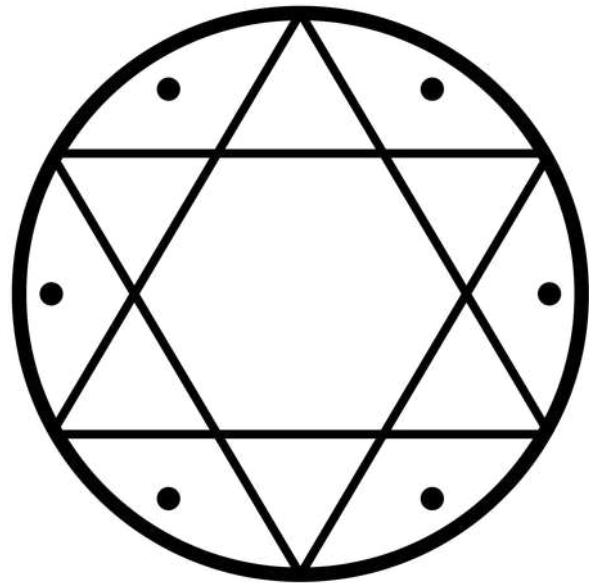

The forward pointing triangle represents the masculine aspect of consciousness while the inward pointing represents the feminine.

The overlap each other to show that they are balanced and harmonized. The two overlapping triangles represent a balanced brain in which the brain halves are communicating and cooperating.

The seal communicates high consciousness and awareness of the knowledge of the mind. The temple of Solomon is the temple of the mind – your mind. It's within you.

Freemasonry is the place and the conditions under which those initiated into the knowledge of the mind meet and practice.



The knowledge about the mind is guarded and kept from the masses. The primary concern of the “occultists” and mind controllers is that we do not have the knowledge of the mind as the knowledge advantage is the foundation on which they build their hierarchies.



The name Solomon contains both the sun and the moon as reference to the masculine and feminine being harmonized.

The official purpose of Freemasonry is self development towards becoming better humans. This is the official purpose and probably also the true purpose for large part of the practitioners.

This is why the two triangles in the seal of Solomon are surrounded by a circle.



A circle is a feminine form which means that the mind is governed by the feminine principles of care and love.

The seal of Solomon, including the circle, is the seal of the spiritually awakened mind – and the way to reach that state is by unifying the masculine and the feminine aspects of consciousness. To unify action with emotion and become beings that think as we feel as we act.

Mind, body and soul; thought action and emotion all unison.

Three out of three. Not only two out of three, which bring us to the three expressions of consciousness.

Three expressions of consciousness

The three expressions of consciousness are thought emotion and action.

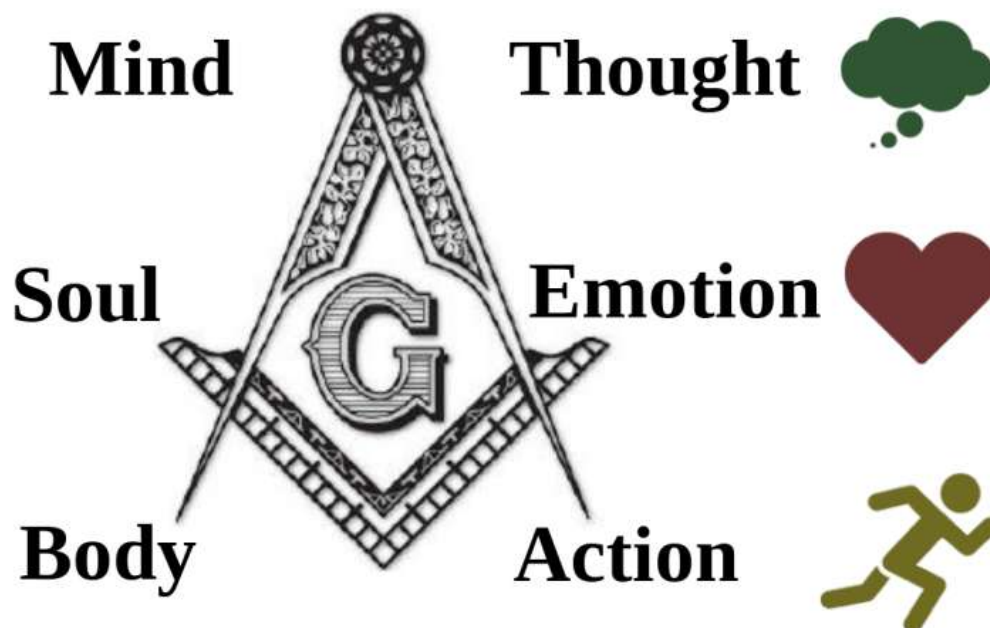
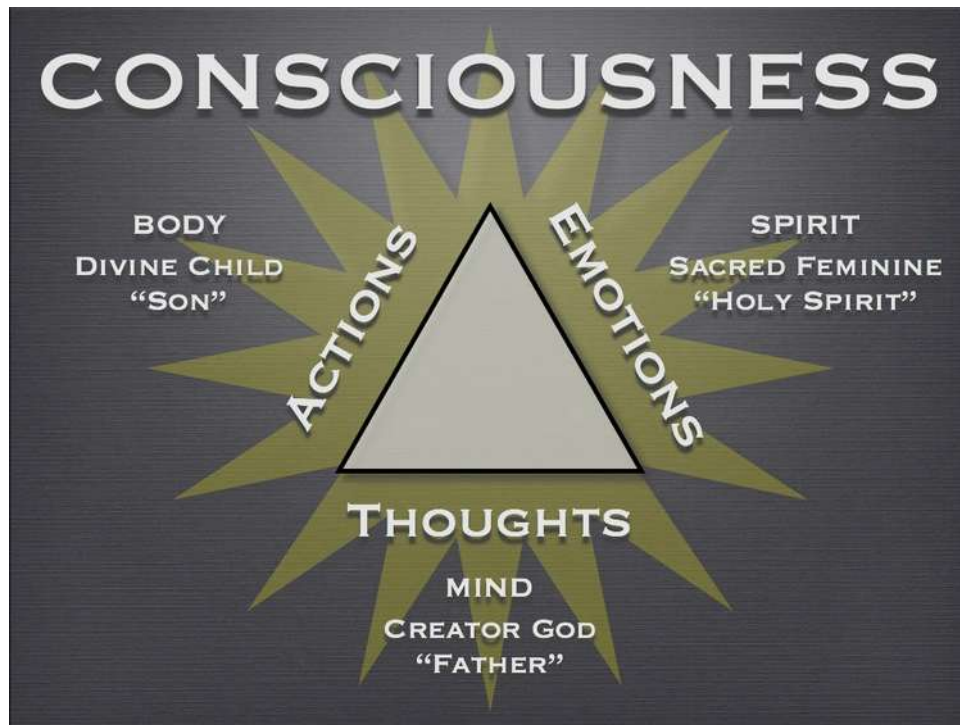



Thought is the primary expression of consciousness. It is an emanation.

Thoughts are neither male nor female: not an internal nor external an manifestation but an essence. They are the fundamental basis of consciousness.

Thought is the creator aspect of consciousness.

Everything that we experience has at some time began as a thought. Any action we take had to first arise as a thought. Thoughts are neither masculine nor feminine.



Emotion is the second expression of consciousness. It's the sacred feminine quality; the internal aspect of consciousness. How we express ourselves, inside the body, through how we feel.

Thought and emotion come together to create action.

Thought provokes an emotional sensation and response that is a mixture of love and fear. The state of our consciousness determines to what extent our thoughts provoke sensations and responses of love and fear respectively. The higher the consciousness the more love. The lower the consciousness the more fear.

Emotion is the spirit in which we do things. In the trinity we call it the holy spirit.



Thought and emotion come together to generate action and behaviour. Action is the child of the interaction between thought and emotion.

In a low, fear based state of consciousness our actions will be geared towards our own survival and material comfort.

In a high, love based state of consciousness our thoughts will provoke emotional responses of love. As the interaction between thought and emotion is love based, so is the action that it generates.

As fear is separation and self interest love is oneness and compassion. Action based in love will be moral, in accordance with natural law and geared towards alleviating suffering and fear, and thereby raising the consciousness of humanity.

Many “light” mystery and occult traditions see the evolutionary progression of human kind as the purpose behind creation and the Will of God. They see it as the only true purpose and therefore the only purpose worth pursuing.

The triune brain:

The three expressions of consciousness are associated with three different evolutionary levels or different complexes of the brain.

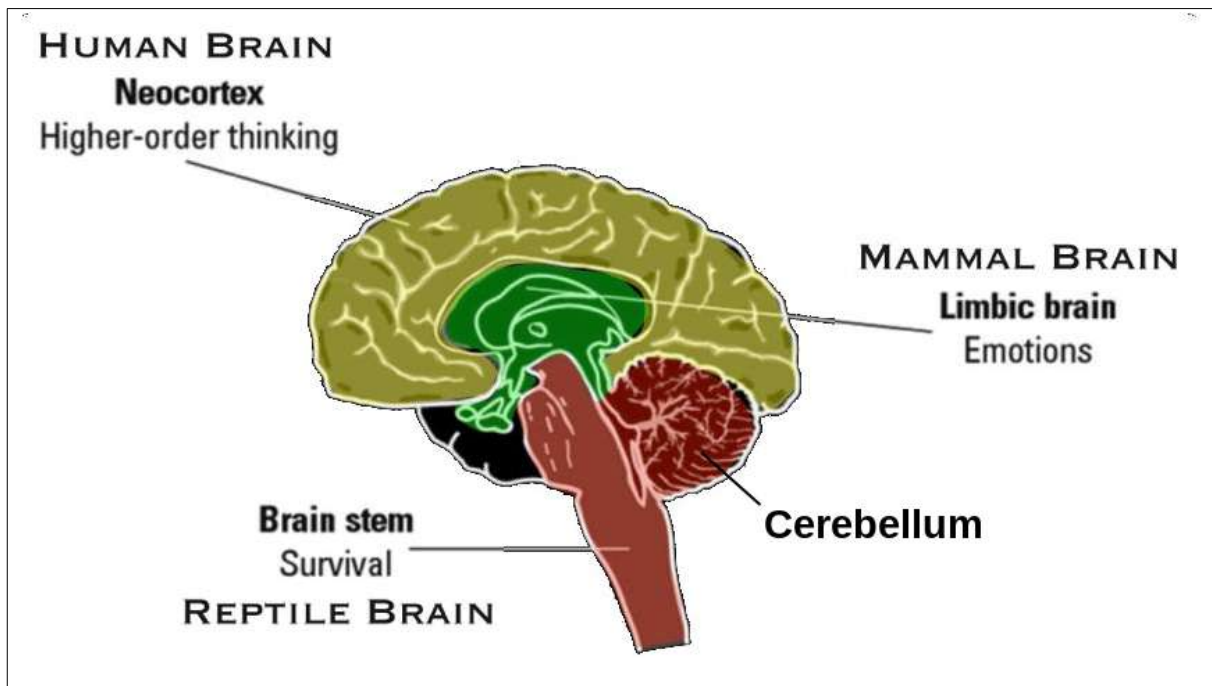

The oldest and least advanced part of the brain is the reptilian brain or the R-complex.

The R-complex consists of two parts. There is the brainstem that connects to the spinal column and there is the cerebellum in the back of the head.

The R-complex is usually referred to as the reptilian complex or the reptilian brain. It governs physical activity and motor skills as well as basic body functions like hunger, eating and sleeping.

The reptilian brain is associated with the physical world and the third expression of consciousness: action.

In body, mind and soul the reptilian brain represents body.

The reptilian brain is also in charge of something called the fight or flight response. It's a primal response that gets activated when we encounter predators in the wild and either have to fight them or run away from them. The fight and flight response is one of the cornerstones of mind control as will be explained further down.

Fight-or-flight response

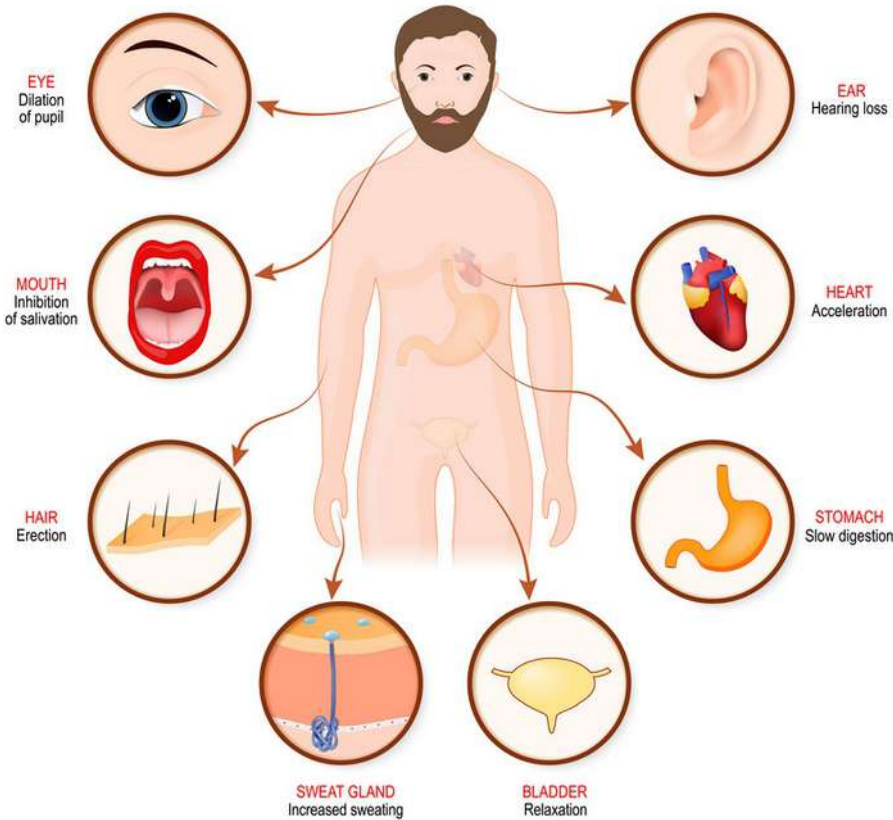

The next part of the brain is the mid brain, the limbic system or the mammal brain. It governs the chemical interactions through which we experience our emotions within the body.

The limbic brain is located in the middle of the brain

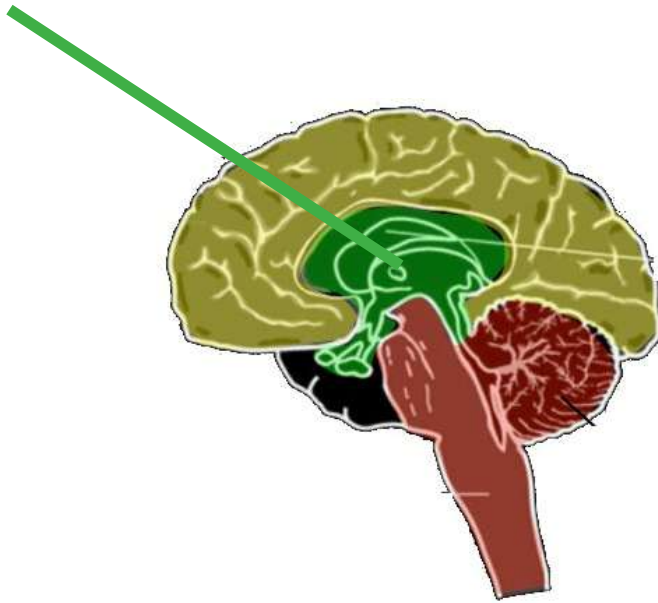

The limbic brain is associated with the sacred feminine, internally felt quality of consciousness. It's sometimes referred to as the mid brain or the middle chamber.

The mammal brain is associated with the soul in body, mind and soul. It is of course also associated with emotion: the second expression of consciousness.



The third part of the brain is the neocortex or the telencephalon usually referred to as the human brain or the primate brain.

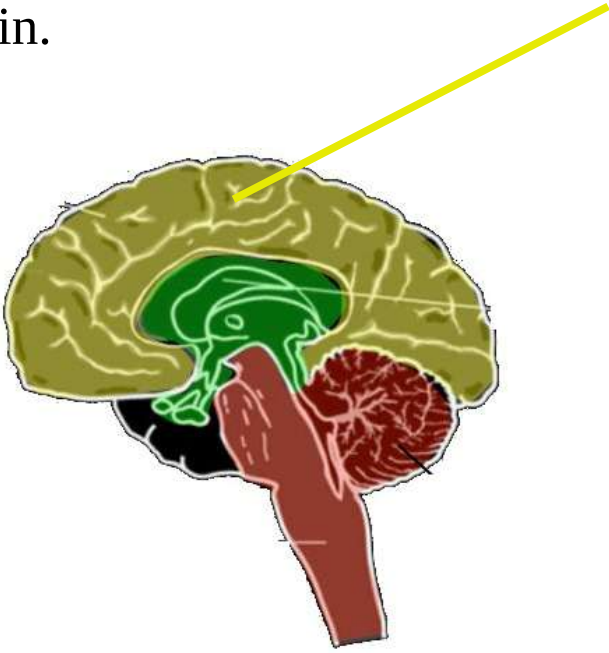

The neocortex is the largest and most advanced part of the brain. It governs abstract higher order thinking and all other functions that animals lack.

The neocortex is as mentioned bilaterally symmetrical with a masculine left brain half and a feminine right brain half.

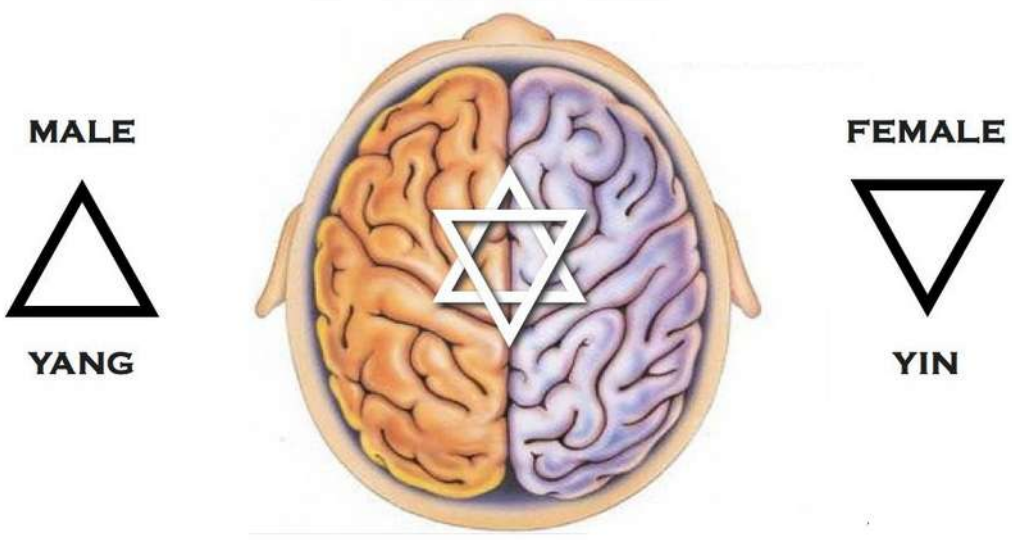

☆	🌿	MIND - THOUGHT - NEOCORTEX
▽	❤️	SOUL - EMOTION - MIDBRAIN
△	🏃	BODY - ACTION - R-COMPLEX

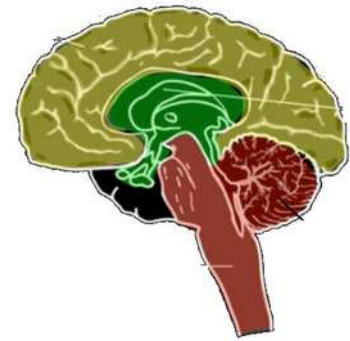

There is a hierarchy to how the brain should function and a way that information should pass when the brain is balanced.

The human brain is designed to be the command centre of the whole brain complex. The mammal brain is constantly sending data upwards to the human brain. The human brain then handles that data and sends instructions for action to the reptilian brain.



If we are in a state of internal opposition and confusion then the neocortex is not functioning properly. One brain half is dominating the other. The communication between the masculine and feminine is obstructed by fear and illusion.

When the neocortex does not function as it should it ceases to be the command centre of the whole brain complex and one of the lower brains take over command of consciousness.

If the masculine left brain is dominating the right brain and prevents it from coming to expression then the limbic or mammal brain will start to shut down. As we need the mammal brain to experience emotions the result is that we become less empathic and compassionate.



As the neocortex is dysfunctional and the limbic brain is shutting down the reptilian brain will take over command over consciousness.

Fight or flight

The reptilian brain is as mentioned in charge of our survival and all that we need to survive in our physical bodies. One aspect of this is the fight or flight response. It's a primal response that gets activated when we encounter predators in the wild, when our survival is threatened and we either have to fight the predator or run away from it.

The response consists of a release of adrenalin to make the heart pump faster and increase our rate of breathing. We need highly oxygenated blood to reach our arms and legs so that we can either fight or run. Blood flow is therefore directed away from the brain and the torso and instead towards the arms and legs.

In the brain blood is directed away from the human brain and towards the reptilian as we do not need to engage in any abstract, philosophical thinking when faced with the predator.

The reptilian brain takes over consciousness temporarily because we need to fight or run so that we can get away from the danger and in safety return to a normal state.

FIGHT OR FLIGHT

NOTICEABLE EFFECTS



Pupils Dilate

Tunnel Vision

Constant Surveillance of Surroundings

Breathing Becomes Fast & Shallow

Heart Beat is Faster and Noticeable

Increase Sweating

Insomnia

ADD/ADHD type Symptoms

Mouth Gets Dry

Inhibition of Erections

Neck, Shoulder and Arm Muscles Become Tense and Stronger

Leg Muscles Become Tense and Strengthened

Fight or Flight

Hidden Effects



Cortisol Released Increasing Blood Pressure and Blood Sugar While Depressing The Immune System

Adrenaline Released to Increase Strength for Fight or Flight

Brain Gets Body Ready For Action Which, in Turn, Prevents Sleep

Liver Releases Glucose for Muscle Fuel

Digestion Slows or Stops

Urine Production Slows or Stops

Oxygen, Nutrients and Blood Flow Shunted to Muscles

That's the fight or flight response. In modern society we rarely encounter physical threats, instead we have something called stress. The physiological response to stress is the same as the fight or flight response.



The difference is that the stress of the modern society can neither be fought or fled. Many people are stressed and worried for a large part of the day, every day.

The fight and flight mind state becomes chronic and they live in the reptilian brain and consciousness.

Brain imbalances.

There are three expressions of consciousness and they correspond to the three different brain complexes.

We have the reptile brain for action, the mammal brain for emotions and the human brain for thoughts.

The reptile brain, known as the r-complex is responsible for motor skills, instinct, survival and fight and flight as just mentioned. The reptilian brain handles the stress mode of the brain.

Above the reptile brain is the mammal brain. It enables us to experience emotions in the body.

The human brain, also known as the neocortex is responsible for higher order thinking, conceptual thinking and conceptual ideas. It enables us to experience reason, compassion, logic, creativity, language, science, art, music and so on.

The neocortex has two halves or hemispheres. A left and a right one. It is bilaterally symmetrical.

The left side governs some functions and qualities, and makes them possible in our thoughts and behaviours. The right side of the brain governs a different set up of functions and qualities.

The left brain half functions as the male component of the brain or the male side of consciousness. It governs logic, science, language and analytical thought. Everything that is rooted in the physical world; the world of words and matter. The left brain governs dealing with everyday physical situations, tasks, movements and things in the visual and sensory field.

The right brain governs holistic thought functions. It governs the feminine, holistic, intuitive nurturing qualities of the individual. It also governs our ability to be creative beings and engage in art, music and dance. Anything that is creative and expressive. This is the right side which can be seen as the feminine counterpart to the masculine left side.

Neither one of these hemispheres should dominate the other given a perfect situation and a brain that is balanced and working as it should.

We should have all those functions in our repertoire of thinking, so to speak.

We need to engage all of these qualities and functions in balance. That is the key to a properly functioning brain and to truly bringing consciousness online.

If we don't engage the both brain halves in balance we will create a brain imbalance and experience negative consequences. The nature of these adverse consequences depends on what brain half is dominant and how severe the imbalance is. The examples below show what happens in the case of total or close to total imbalance.

If a person through their interactions with other people, through the media they take in, the material they look at, their general behaviour and experience in the world; if they become a person who almost only engages the physical world and every day occurrences, and never uses the creative, intuitive and spiritual side of the mind, no deeper thoughts and no expression through art or music, then left brain completely dominates the neocortical functions of the brain and the right brain suffers as a consequence of this.

In this state of imbalance the whole neocortex, the higher order thought centre of the brain, starts to dysfunction and becomes incapable of fulfilling its intended role as the executive command centre of the whole brain complex. This means that one of the lower brain functions has to take over that command.

Envision any company with an central executive officer (ceo) that makes the executive command decisions for the direction the company. The executive officer holds this position because he or she has the skills and the knowledge needed to take those decisions.

If that ceo was suddenly to become so ill that he or she no longer could fulfil the obligations and responsibilities to the company then middle management would have to step in and take over those responsibilities.

The neocortex is supposed to be the ceo of the brain complex as the two lower brain functions are not as advanced and do not have the same capabilities.

If however the brain is destabilized towards left brain hemispherical imbalance in which the left brain becomes completely dominant over the right brain hemisphere, then the neocortex suffers and becomes damaged. This damage is physical and measurable with modern instruments.

In the imbalanced brain neurons don't fire as they should and new neuron connections are not created in a proper way. Areas of the brain become darkened as there is no electrochemical and neural activity taking place. The neocortex can no longer make good reasonable executive decisions. It is damaged so middle

management has to step in and take over those functions.

The left brain becomes dominant when we dominantly engage the left brain. This means that we are not using the feminine right brain and the feminine mammal brain suffers as a consequence. It ceases to function as it should and sending the chemicals that help us to experience our emotions into the body. We no longer experience emotions in the same way that a healthy and holistically functioning brain would.

As the neocortex is dysfunctional and the mammal brain is shutting down the reptile brain takes over command.

The left brain that only deals with the physical world without consideration to the spiritual, intuitive and creative; when that dominates the persons thoughts, the emotional centre of the brain suffer the most and the reptilian brain, survival, stress and fight and flight part of the brain takes over the entire consciousness of the individuals brain.

It becomes the execute controller of the brain and the person is essentially living in the reptile part of the mind.

This state is what we today consider normal.

When the right side dominates.

If the person lives chronically in the spiritual, intuitive and creative, and is never rooted and never grounded in the sense that they consider happenings in the physical domain as important; if they are always living in the other world and the world to come...

or if they only live for basic pleasures without looking at anything negative or that could be considered as dark, not engage problems but live in escapism, then the right brain becomes dominant. When this happens the limbic or the mammal brain runs wild and the person essentially becomes a slave to their feeling and emotions.

When the brain becomes imbalanced towards the right side then the reptile brain is more or less shut down. The part that governs instinct and survival shuts down and the person lives in the mammal brain or the limbic system. They either live in fear or become incapable of discerning what is truth and what is not. They become too passive and allow themselves to be walked on.

The left side imbalance creates a dominator type. They want to control other people, their behaviour and their actions, and they can sometimes become physically aggressive if they don't get what they want.

When the right brain becomes chronically imbalanced you get all of the slave tendencies. A person becomes engages in feelings of unworthiness, self loathing, and never thinking they are good enough. They often develop addictive tendencies.

They become people who are willing to follow whatever order they are given. They become willing slaves.

One form of imbalance creates a dominator while the other form creates somebody who is willing to be dominated.

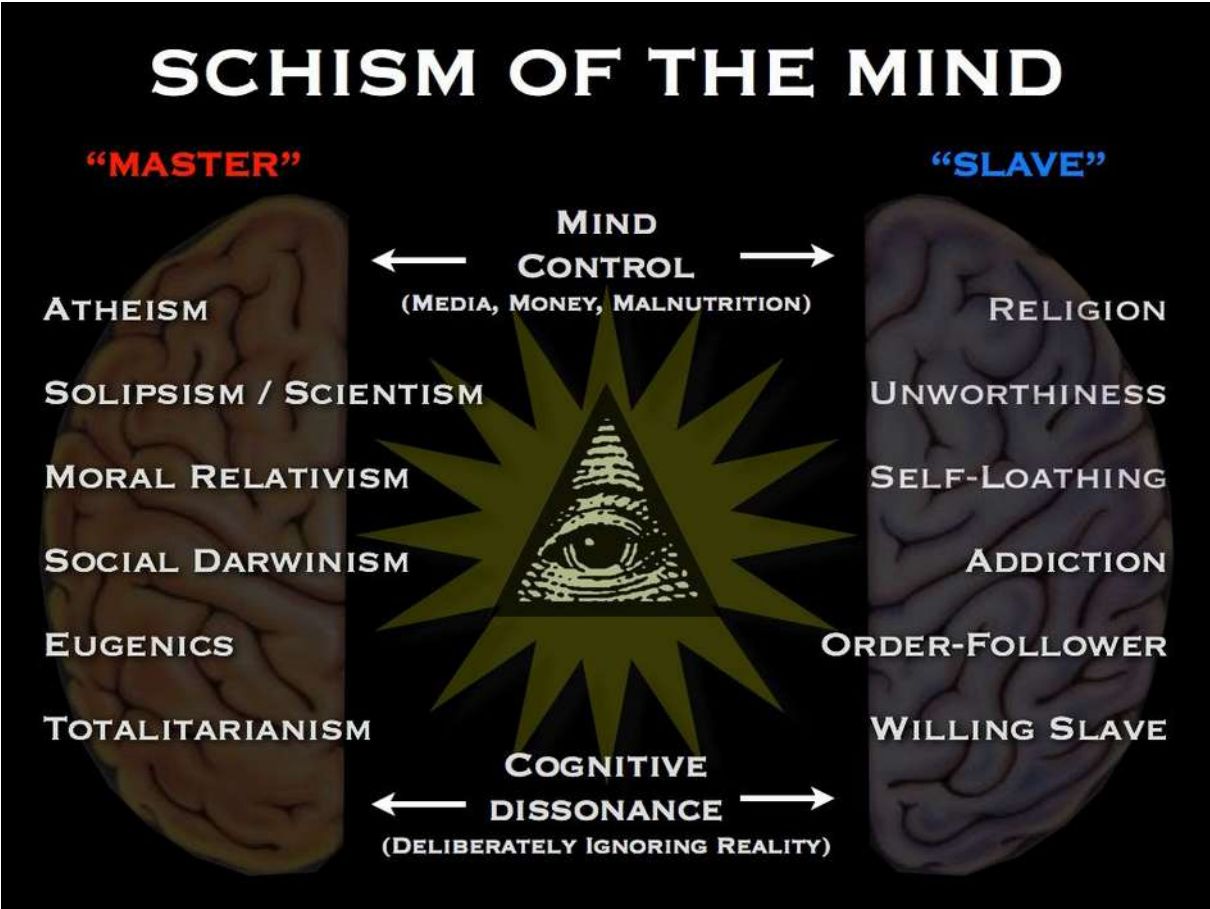

These two form of imbalance can be seen as the functioning of either the masculine or the feminine separate from the other. As an imbalanced brain is a brain in which the brain halves are not communicating and cooperating properly it is not unusual that the individual displays both imbalances. Certain aspects of experience are handled through the left side imbalance while others are handled through the right side imbalance.

One of the imbalances will however be dominating and have the final saying in constituting the persons overall world view and generating our experience.

World view schism:

World view refers to how we view the world we live in and how we view our relationship to the world and to other people.

World view is the driving factor behind what we are creating in our lives. Essentially what we think about most of the time is what we are becoming.

The world view that we hold shapes the events that manifest in our lives. The way we think is critically important to what takes place in our experience.

There are two essential world views that fear wants to put us in. One of these world views is generally held by a persons with a dominant left brain half while the other is held by people with a dominant right half. The world views described below are held by people with extreme imbalances.

The left side dominant brain:

This is called the world view of randomness. It might seem as it should be the schism of the right side dominant brain but this actually the mind of the left side dominant brain trying to compensate for all the control.

The left side dominant world view of randomness sees the universe as the result of a cosmic accident. On it's own the left brain can neither sense nor envision a greater holistic purpose so it believes creation is random and that there is no underlying purpose for existence. Existence is essentially meaningless.

It leads to atheism and either solipsism or scientism. Either the belief that nothing can be known because there is no truth, or the belief that everything can be known using science.

Right brain extreme world view: Determinism.

The world view held by a person who is in a state of internal opposition and has an imbalanced mind is usually the total opposite of the imbalance.

The right brain dominant imbalance holds the world view of total control and total order as a way to compensate for the lack of control and order in the absence of the structure and order of the left brain.

This world view is called determinism and it states that God controls every event in creation, that all occurrences are there preordained and from there they falsely draw the conclusion that free will does not exist.

The right brain imbalance creates a sense of unworthiness that goes together with the belief that one cannot have an impact on the development of events as everything is already determined by God and destiny. When you are in a state of fear the passive and submissive feminine mind will tell you that you don't matter

Both the world views described above are world views of the lower self or of the fear based consciousness of the self opposed being.

They are fear based world views that allow for the individual to escape responsibility as the neocortex is dysfunctional and neither one of the lower functions are capable of carrying true personal responsibility.

The left brain delegates personal responsibility to authority but still tries to remain responsible by actively enforcing the command of the authority to which responsibility is delegated.

The right brain delegates personal responsibility to God. It remains passive in the sense that it sees itself as insignificant in the larger picture where true personal responsibility resides. It's all in the hands of God.

Love and fear:

You are a being of love.

The love inside of you is ever shining like the sun.
Even when your mind is clouded by fear your love still
shines .

Never fear what is inside of you.

Search the truth, even in the darkest of corners, and you
will eventually break through the layer of clouds and
see the ever-shining love within you.

You will know that the same way your love shines
inside of you, so does love shine inside of us all.

Every brother and every sister you meet on the road
carries the same love inside. Most are still clouded by
fears while some shine through in a smile.

Together we will break the wall.

Look someone in the eyes, smile, and hear how it falls.

The night has been dark but now comes dawn

Love and fear are the two basic underlying emotional forces. They are the essence or the primary causers for our emotions.

Love is the essence of everything that we perceive as good, good for us or that feels good within us. It's uplifting.

Love is the desire to experience life and everything that it has to offer. Love loves to see and know more, grow and to learn.

Love is the emotional force that expands consciousness.

Consciousness can be defined as the ability to recognize patterns and meaning with respect to events taking place both within oneself as well as in the realm in which the self exists and operates.

The more patterns and meaning that we recognize and experience the richer will life be.

Love expands and flowers consciousness. It makes the mind search new patterns.

The other emotional force is fear. It's compressive meaning that it closes consciousness down. It makes you not want to look, see, understand, care or act.

Fear is the anticipation of negative occurrences. New patterns and new meaning are believed to be negative and cause suffering. New patterns are not sought and the truth is not sought.

There is an internal and an external manifestation to the emotional force of love and there is an internal and external manifestation to the emotional force of fear.

	Internal	External
Love	Self-rulership	Freedom
Fear	Confusion	Control

Love is the force that expands consciousness. When love manifests inside an individual we achieve a state that can be described by several different words; self-love, enlightenment, balance, harmony, internal peace.

The force of love can only manifest inside of us when we bring our thoughts, emotions and actions into unison within us so that there is no internal contradiction within our consciousness, meaning that we think as we feel as we act in the world.

What is going on inside our mind reflects in perfect unison what is going on in our heart centre, these two qualities are not in internal opposition with how we act and behave in the world.

We are true to ourselves, we behave in accordance with own internal moral and emotional compass, so the inevitable outcome is that we love and understand ourselves.

This state of internal self love can also be described using a different set up of words like dominion, self-rulership and sovereignty.

The mind can be seen as the creator aspect of consciousness. All that we create has to first exist as a thought. It is the essence quality.

The soul is the internal manifestation called emotions. We can see it as the spiritual aspect as emotions are the spirit in which we do things.

Then we have an internal manifestation called our emotions. This is the spirit.

We have the creator and we have the holy spirit. Action is the child of thought and emotion. It is a male child as it is active.

This gives us the holy trinity, a creator aspect, a spirit aspect and a male child aspect.

If your thoughts and your emotions are in unison without internal contradiction of opposition then your internal moral and emotional compass determines your behaviour. You yourself rule your mind and your actions. You are the master of yourself and nothing can make you betray your own spirit by acting against it.

There is a word in ancient Hebrew that means the opposer. That word is Shatan, were Satan comes from. It is the force which divides us and puts us into opposition.

When we do something in opposition to how we say that we think and feel then we betray the spirit; we sin against the spirit.

When we take an action for a justification, thinking; "I know I should be doing this but I'm going to do this any ways"; this is the force called Shatan.

It's extremely hard, close to impossible, to be completely united and take the actions that we say we think and feel. It is hard because it requires courage; an immense amount of courage. The world we live in is designed by the master of mind control and it is designed to keep us going against our better judgement and internal feeling of what we should be doing.

The result is that we constantly keep justifying our actions and behaviour thinking that if I don't do this then there will be these repercussions, and if I do that there will be those repercussions.

There is an endless supply of justifications for not doing the correct moral thing in life and the world we are born into is designed to make those justifications far more easy and convenient than the right action.

When the internal indwelling aspect of the force of love comes to flourishing inside an individual is called self dominion. It means that there is no external ownership or rulership. It is dominion of the kingdom of the self.

The only way to come into that state within ourself is if we become beings who think as we feel as we act.

Courage is the strength that is needed to reach that state of internal unison and courage can be cultivated through will and practice.

Will is in turn cultivated and directed by knowledge. The more you understand yourself the closer will you get to your true self. The closer you are to your true self meaning that the more united that your thoughts and emotions are, the more will you validate yourself and your behaviour based on your own internal compass rather than culture and external ideals.

The more you unite within and listen to yourself, the less will you care about the opinion of others.

As you through will and practice increase the communication between your brain halves you raise your consciousness meaning that your thoughts will provoke more emotional responses of love and possibility than of fear.

You simply become a stronger, more confident, moral and happier version of yourself and your experience improves.

There is also an internal manifestation to the force of fear.

A person ruled by is always in internal opposition with themselves. There is contradiction between what they think, how they feel and how they act.

The brain halves do not communicate properly, the person does not see clearly inside and is therefore confused.

When consciousness is ruled by fear the state that results inside is confusion.

Confusion is a state of internal disharmony. Fear shuts consciousness down and cuts us off from higher levels of awareness. Someone in this condition is not capable of knowing truth from falsehood. They don't know what is going on inside of them, they don't see clearly, the neocortex is not in command, so they become incapable of telling truth from falsehood. They cannot discern what is illusion and what is reality.

Someone in confusion does not really love themselves. They don't have internal love. Internally dwelling self love. Their actions do not match their feelings, they are not true to themselves, so they don't love themselves.

As they don't know what true sovereignty and freedom are, and as they don't know what they themselves are,

they can be made or lead to do anything. Their psychological make up is frail and weak. They are led.



A person governed by fear will always be in a state of confusion which is internal opposition. The internally manifesting quality of fear.

The external manifestation of love.

When love is present and has grown to a great extent in many individuals there is a state that comes online; a condition that burst onto the world. If the true essence of love is carried within many individuals who truly understand what takes place inside of themselves, and live in a way that is reflected by the notion that they think as they feel as they act, then the condition that will eventually erupt onto the world is called freedom.

Freedom is the external manifestation of the love force. It is the state that will occur when enough individuals come to a state of internal dominion because they have made the active free will decision to take actions that are in keeping with their thoughts and emotions, and can not be made to go against what they feel in their heart is right.

The external manifestation of the force of fear.

Fear is the force which shuts consciousness down and puts us into a state of internal confusion and opposition. When that state dominates the external reality so that many people are not self governed and not governed with truth but in a state of opposition, then the condition that manifests externally is control.

The instinctive response to fear is control. We want to control that which we fear. When the state of fear becomes chronic so does our need to control.

External control is when people try to control the actions of other; even those who are not doing anything harmful. When people in a state of fear and confusion obey authority then you get a hierarchical world of control and external domination.



The third eye

When thought, emotion and actions comes into harmony within the being, resulting in the state of dominion or self-rulership, the third eye becomes activated.

The third eye is the human pineal gland exactly in the middle of the brain, inside the limbic system.

The pineal gland has got it's name because it is shaped like a pine cone. It becomes active and awakens a human being to higher states of awareness of what is going on inside of them as well as around them.

It is done by balancing the brain hemispheres.



The pineal gland is by some referred to as the seat of the soul. This gland is can be seen as the connection to the divine or from an atheistic view point as the gland that generates divine sensations.

The pineal gland has got it's name because it looks like a pine cone. The largest statue in the Vatican is called the pine. It is a huge pine cone with two smaller peacocks on each side.



The two similar sized peacocks on each side of the pine cone represent the balanced right and left brain.

Peacocks because the brain and the consciousness has flowered out in beauty.

The huge pine cone of course represent the activated pineal gland and the connection to the divine.

What you don't see as a visitor is that on the floor behind the pineal gland and the peacocks lies a casket. A casket is a symbol for the dead or in the context of occult knowledge of the mind it represents the lower fear based consciousness.



The whole statue, including the casket then represents a spiritual awakening. The individual has arisen from the dead into the world of those spiritually alive.

**We have, built into our physiological make up, the ability to experience the sensation of a connection to the divine. This ability comes online when we are pure inside in the sense that our actions are moral and based in love.

We also have, built into our physiological make up, a higher state of being that can only come online when we believe there is more than meets the eye and the four other senses. We have a higher state of being that only comes online when we believe there is a higher purpose and meaning.

The True Self

The True Self cannot be anything else than the unclouded consciousness of the self unified individual.

The true self is not in a state of internal opposition but of internal unison and dominion. The true self is the master of the temple within.

Internal unison comes to expression in actions that are in accordance with emotion and thought. The true self thinks as she feels as he acts regardless of the price.

The true self is true to itself and it therefore loves itself. As there is no opposition or conflict within there is neither any confusion. The individual sees clearly and therefore understands herself as well as others.

The true self understands that every human carries an internal sun of love and that the only reason that sun does not come to expression is because of fear.

Bad, negative and harmful behaviour is always fear based. Any person expressing such behaviour do so because they themselves fear. When we understand this we can see beyond it, we can see the sun behind the clouds in every person we meet.

In the true self the human brain or the neocortex is functioning properly and therefore the command centre of the brain.

The individual accepts no outside authority as he is the master of his own temple. He takes full responsibility, not only for him or herself but for all of life.

True self - Unison consciousness (Human brain in command)	Cares for all living beings
---	--------------------------------

Mammal brain in command Emotional	Cares for own group
--------------------------------------	------------------------

Lower self - Separation Reptile brain in command Survival mode	Cares for self
---	----------------

In the true self a properly functioning neocortex is in command. This means that a unified masculine and feminine brain is in command. Emotion, thought and action in harmony. The individual sees clearly inside as well as outside, is true to itself and will therefore trust itself more than it trusts any outside claim at authority. It recognizes patterns, incorporates both detail and holistic thinking and can therefore discern truth from falsehood.

The true self is active. It is driven by purpose and that purpose is love. The true self is driven by empathy and compassion. As the masculine and feminine is unified the brain is fully capable of reasonable thinking and the individual will therefore make their own assessment of the world they live in and how best to work towards the alleviation of suffering of humanity and all living beings.

CORONA

$$\begin{array}{r} C = 3 \\ O = 15 \\ R = 18 \\ O = 15 \\ N = 14 \\ \hline A = 1 \\ 6 \quad 66 \end{array}$$

$$\begin{array}{r} C = 3 \\ O = 15 \\ V = 22 \\ I = 9 \\ D = 4 \\ 1 = 1 \\ \hline 9 = 9 \end{array}$$

$$63 = 6 \text{ 3 veces} = 666$$

666 escondido en ambos. La ideología del psicópata..

$$4 \times 4 = 16,$$

$$7 \times 7 = 49,$$

$$16 + 49 = 63$$

$$4^2 + 7^2 = 63$$

$$47 + 7 + 9 = 63$$

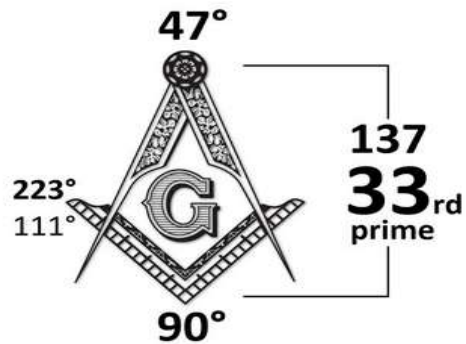

The number of the beast!

Imagine that you are born into a bloodline that for millennia has used dark methods to gain power and wealth. You are born into the top of the pyramid; into an extremely small minority that dominates the world through mind control.

Your ancestors are behind all the poverty, wars and atrocities that have plagued humanity throughout history.

Imagine that this is the life that you inherit. The conditions that you are given by birth into this bloodline is that your survival depends on the mind control holding up. If the truth comes out then you and your kind are doomed.

You are born into an environment totally structured around fear, and there are of course traditions on how to bring you up to become a worthy member of the ruling dynasty.

You and your kind have to keep the manipulation and violence going. You have to keep the system broken to keep the people down. You have to be emotionless, totally in your reptile mind, to survive.

Your kind holds all the knowledge of the mind. You know the dynamics of love and fear better than anyone else. You know that you are a being of fear and that we

who love, we see love as the most precious thing in life. Love is what gives life meaning, but you cannot love, because if you love you will suffer tremendously for you actions, you will do the right thing and you will get killed for it.

When you rule the world, your only way to survival is to destroy the love inside of you. Those who managed to do this, and create the traditions through which their offspring are deprived of love, they rule the world we live in.

They know, and they will always know, that no matter how wealthy and powerful they are, we would never change with them. In a state of fear and ignorance we might believe we want to be in their position, would we however have the knowledge that they have, then we would never change.

Do you think they will hold a world view that understands them as inferior to us? Or do you think they will create an ideology that holds them as superior?

Satanism is not devil worship. Not the kind of Satanism that is used to control the conspiratorial pyramid.

Satanism can best be described as an ideology built around the right of the strong to dominate the weak. If you are the star, then you shine as bright as you can, they say.

If you are the strongest, then it is your right and your duty to prioritize the survival of your offspring and your blood. It's strength, not love, that is the will of god. It's your duty to control who lives and who dies; who gets to reproduce and who doesn't. Empathy, compassion and shame are for the weak and they have to be eliminated. Emotions do not serve domination, they need to be eradicated.

In it's essence, Satanism is the war on the soul.

As the soul is out of their reach, the mind and the body are what that they have got to work on. Satanism is the war on the soul and that war is waged in the form of mind control.

We talked about NASA in the first chapter and how their logo gives reference to masonry. We will now look at the gematria for NASA, or National Aeronautics and Space Administration.

National Aeronautics and Space Administration Match

English Ordinal	Full Reduction	Reverse Ordinal	Reverse Full Reduction
441	171	666	261
9	9	9	9

(41 letters, 5 words)

"National Aeronautics and Space Administration" = **441** (English Ordinal)

N	a	t	i	o	n	a	l	86	A	e	r	o	n	a	u	t	i	c	s	126	a	n	d	19	S	p	a	c	e	44
14	1	20	9	15	14	1	12		1	5	18	15	14	1	21	20	9	3	19		1	14	4		19	16	1	3	5	

A	d	m	i	n	i	s	t	r	a	t	i	o	n	166	441
1	4	13	9	14	9	19	20	18	1	20	9	15	14		

The first thing that hits your eye is that the reversed ordinal of NASA is 666.

"National Aeronautics and Space Administration" = **666** (Reverse Ordinal)

N	a	t	i	o	n	a	l	130	A	e	r	o	n	a	u	t	i	c	s	171	a	n	d	62	S	p	a	c	e	91
13	26	7	18	12	13	26	15		26	22	9	12	13	26	6	7	18	24	8		26	13	23		8	11	26	24	22	

A	d	m	i	n	i	s	t	r	a	t	i	o	n	212	666
26	23	14	18	13	18	8	7	9	26	7	18	12	13		

The ordinal is 441.

$$6 \times 6 \times 6 = 216$$

$$5 \times 5 \times 5 = 125$$

$$4 \times 4 \times 4 = 64$$

$$3 \times 3 \times 3 = 27$$

$$2 \times 2 \times 2 = 8$$

$$\underline{1 \times 1 \times 1 = 1}$$

441

We have a hidden 666 and a blatant 666.

The reduced ordinal is 171. A 7 in between two pillars.
A G between two pillars.

This is absolutely astonishing. How could they find a name that gives a double reference to 666 while also holding the 7 between two pillars. It's amazing.

The number 666 is for 66,6%

You are body, mind and soul. You are 3, the holy number.

66,6% of 3 is 2.

As 3 is body, mind and soul, 2 will be only body and mind.

Remove the soul and you get 66,6%, or 666.

The full human is 777. In the masonic logo we have the compass and the square as visual references to 7 while the G is the 7th letter. It holds 777.

The number 77 is hence equivalent of 666 in the sense that it only refers to the body and mind. 77 is just as 666 the absence of the soul.

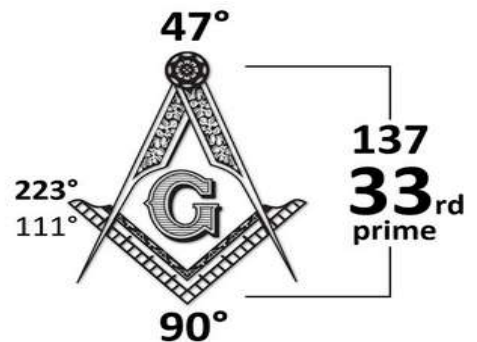

The G in the masonic logo can be seen as holding 223 degrees. 223 is to be read as 2 to 3. This is the number of the spiritual awakening. It is to go from 2 to 3; from body and mind to body, mind and soul.

George Bush, the president who served during nine eleven, is a confirmed member of the secret society called Skull n Bones.

In the logo of Skull n Bones you find a skull and two bones. This is symbolize body and mind. The being is dead, meaning the soul is dead.



Under the Skull n Bones is written the number 322. This is the opposite of 223. It is to go from 3 to 2. From body, mind and soul to only body and mind.

Nine eleven happened when 111 days remained until the end of the year. 111 from completion.

111 is the difference between 666 and 777.
777 is completion, 666 is the absence of the soul.

666 is 111 from completion. Nine eleven happened on 111 from completion.

The two planes that hit the twin towers, or the towers of the mind, carried 157 passengers. 1:57 is 3 minutes to 2.

157 can be seen as 322.

In nine eleven 343 firefighters died before building 7, the 47 storey high salomon brothers building came falling down.

343 is $7 \times 7 \times 7$.

They were firefighter and they died before building 7, the soul, came falling down due to fires in the basement or fires from below.



The total amount of dead is according to many sources 2996.

2996 can be seen as to 996 or to 666.
2666 would be to blatant as the final death count.

This document is not completed yet, and it will most probably never be completed. What you have read so far is the result of a life long dedication. What I have showed you is already enough.

There is however one thing that needs to be mentioned and understood. The only way to get the number 322 as a date is 3/22. That's the only way, and that's the date when the Georgia Guidestones (GG) were opened.

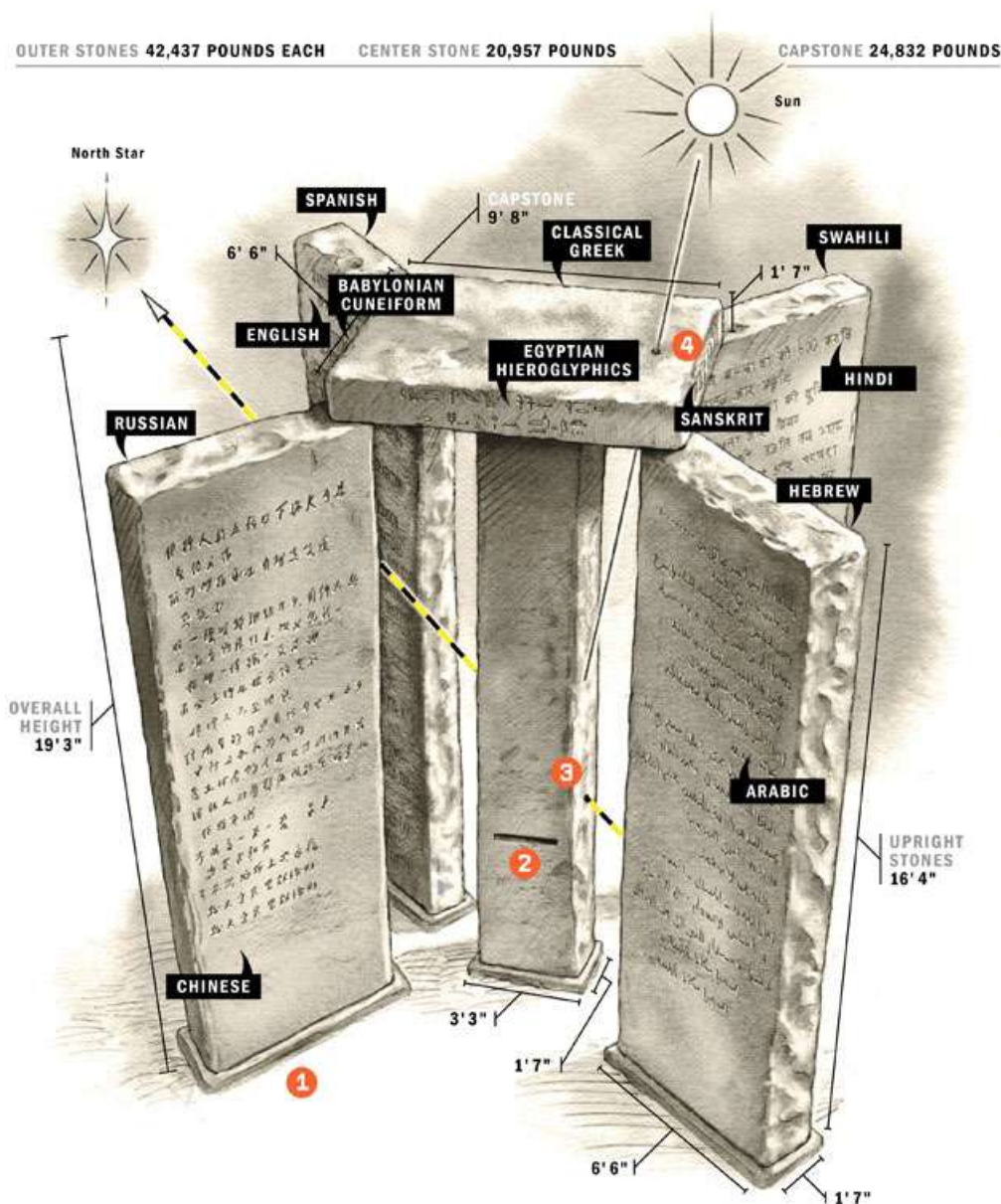

Appendix:

1. The numerological pattern

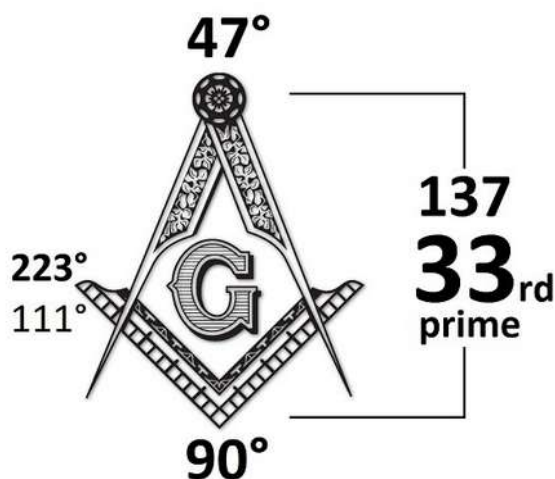

There are three parts to the numerological pattern built around the Masonic logo.

1.1) We have combinations of the 47 of the compass and the 90 of the square in different creative ways. Sometimes the 7 of the G is added.

1.2) We have all the different G's in a continuous alphabet: 7, 33, 59, 85, 111, 137, 163, 189, 215, 241, 267, 293, 319....

1.3) And we have the degree structure of the Scottish and York rites of freemasonry: 33 & 4×13

Appendix 1.1

Creative combinations of the 47 of the compass and the 90 of the square. Sometimes including the 7 of the G

The number 47 can be turned into: 3, 11, 28 and 47

$$3 = 4-7 \quad 11 = 4+7 \quad 28 = 4 \times 7 \quad \text{and} \quad 47$$

The number 90 can only be turned into 9.

If we combine the different numbers that 47 can be turned into with the different numbers 90 can be turned into then we get the following table:

	3	11	28	47
90	39 / 93	101	118	137
9	39 / 93	9-11	37	56

If we also add the 7 of the G we get this table:

	3	11	28	47
90 + 7	100	108	125	144
9 + 7	19	27	44	63

These numbers constitute the first part of the pattern.

Appendix 1.2

The different G's in a continuous alphabet.

- 7
- 33 (Everywhere)
- 59
- 85 (Twin towers)
- 111 (Masonic logo)
- 137 (Masonic logo)
- 163 (Make Americ..)
- 189 (Pentagon)
- 215
- 241
- 267
- 293
- 319 (Oslo attack)

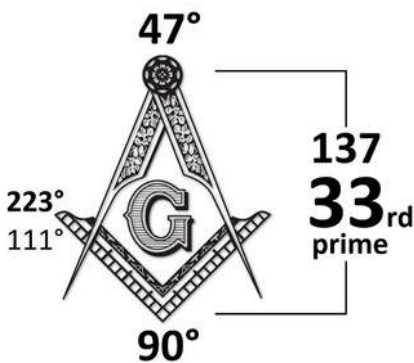

	A	B	C	D	E	F	G	H	I	J	K	L	M	N	O	P	Q	R	S	T	U	V	W	X	Y	Z
1st alphabet	1	2	3	4	5	6	7	8	9	10	11	12	13	14	15	16	17	18	19	20	21	22	23	24	25	26
2nd alphabet	27	28	29	30	31	32	33	34	35	36	37	38	39	40	41	42	43	44	45	46	47	48	49	50	51	52
3rd alphabet	53	54	55	56	57	58	59	60	61	62	63	64	65	66	67	68	69	70	71	72	73	74	75	76	77	78
4th alphabet	79	80	81	82	83	84	85	86	87	88	89	90	91	92	93	94	95	96	97	98	99	100	101	102	103	104
5th alphabet	105	106	107	108	109	110	111	112	113	114	115	116	117	118	119	120	121	122	123	124	125	126	127	128	129	130
6th alphabet	131	132	133	134	135	136	137	138	139	140	141	142	143	144	145	146	147	148	149	150	151	152	153	154	155	156
7th alphabet	157	158	159	160	161	162	163	164	165	166	167	168	169	170	171	172	173	174	175	176	177	178	179	180	181	182
8th alphabet	183	184	185	186	187	188	189	190	191	192	193	194	195	196	197	198	199	200	201	202	203	204	205	206	207	208
9th alphabet	209	210	211	212	213	214	215	216	217	218	219	220	221	222	223	224	225	226	227	228	229	230	231	232	233	234
10th alphabet	235	236	237	238	239	240	241	242	243	244	245	246	247	248	249	250	251	252	253	254	255	256	257	258	259	260
11th alphabet	261	262	263	264	265	266	267	268	269	270	271	272	273	274	275	276	277	278	279	280	281	282	283	284	285	286
12th alphabet	287	288	289	290	291	292	293	294	295	296	297	298	299	300	301	302	303	304	305	306	307	308	309	310	311	312
13th alphabet	313	314	315	316	317	318	319	320	321	322	323	324	325	326	327	328	329	330	331	332	333	334	335	336	337	338